

**CONFIDENTIAL**



**UNIVERSITI TUN HUSSEIN ONN MALAYSIA**

**FINAL EXAMINATION  
SEMESTER II  
SESSION 2012/2013**

COURSE NAME : CONTROL SYSTEM  
COURSE CODE : DAE 32103  
PROGRAMME : 3 DAE / DAL  
EXAMINATION DATE : MARCH 2012  
DURATION : 2 ½ HOURS  
INSTRUCTIONS : ANSWER **FOUR (4)** QUESTIONS ONLY

THIS QUESTION PAPER CONSISTS OF EIGHT (8) PAGES

**CONFIDENTIAL**

- Q1** (a) Describe the meaning of
- (i) Control system.
  - (ii) Control system component.
- (5 marks)
- (b) Give the advantages and disadvantages of the following control system
- (i) Open loop control system.
  - (ii) Closed loop control system.
- (14 marks)
- (c) There are six (6) steps involved in designing a control system. Briefly describe the control system design process.
- (6 marks)

- Q2** (a) List three (3) types of time domain input function and sketch the graph respectively.
- (6 marks)
- (b) Solve the ramp response for a system whose transfer function is

$$G(s) = \frac{s}{(s+4)(s+8)}$$

(15 marks)

- (c) Draw the free-body diagram of the spring mass damper system as shown in Figure Q2(c).
- (4 marks)

- Q3** (a) The polynomial function is given.

$$F(s) = \frac{(s+2)(s-3)(s-6)}{(s+3)(s-1)}$$

Plot the poles and zeros for the system.

(5 marks)

- (b) The transfer function of a position control system is given by;

$$\frac{\theta_o(s)}{\theta_i(s)} = \frac{100}{s^2 + 18s + 100}$$

Calculate the damping ratio, ( $\zeta$ ) and natural frequency, ( $\omega_n$ ). State the types of system response then solve;

- (i) Peak time  $t_p$
- (ii) Percent overshoot,  $\%M_p$
- (iii) Rise time,  $t_r$
- (iv) Settling time  $t_s$  for 5% criterion

(20 marks)

- Q4** (a) Data acquisition is the process of sampling signals that measure real world physical conditions and converting the resulting samples into digital numeric values that can be manipulated by a computer.

- i) Sketch a complete block diagram of data acquisition system.
- ii) Explain the function of each component based on your block diagram.

(16 marks)

- (b) Calculate the output of 10-bit ADC when the input voltage  $V_{in}$  is 2.5 V and reference voltage,  $V_{ref}$  is 5 V.

(4 marks)

- (c) Sketch a schematic diagram of n-bit DAC using R-2R ladder circuit.

(5 marks)

- Q5** (a) List four (4) types of ADC that most frequently used.

(4 marks)

- (b) The main function of a digital controller is to control the closed loop response of a system. Sketch a structure of a digital controller.

(5 marks)

- (c) There are three (3) possibilities spectrum of a sampled signal according to Shannon's sampling theorem. Identify and sketch the three (3) possibilities spectrum.

(6 marks)

- (d) Consider Figure Q5(d) is an example of Digital Control System which utilizing a microprocessor-based controller with parallel ports. This system has one output port and three input ports (each port has each own address). Based on Figure Q5(d), explain the system operation of this system.

(10 marks)

- Q6** (a) Give three (3) types of process control loop other than open loop and closed loop.

(3 marks)

- (b) (i) List three (3) types of temperature measurement.  
(ii) Give one example respectively.

(6 marks)

- (c) (i) Give two (2) types of thermistor.  
(iii) Explain the relation between the temperature and the resistance value for each type of thermistor.

(4 marks)

- (d) Explain Bourdon Tube working operation based on Figure Q6(d).

(12 marks)

- END OF QUESTION -

**FINAL EXAM**

SEMESTER/ SESSION : SEM II / 2012/2013  
 COURSE : CONTROL SYSTEM

PROGRAMME : 3 DAE / DAL  
 COURSE CODE : DAE 32103

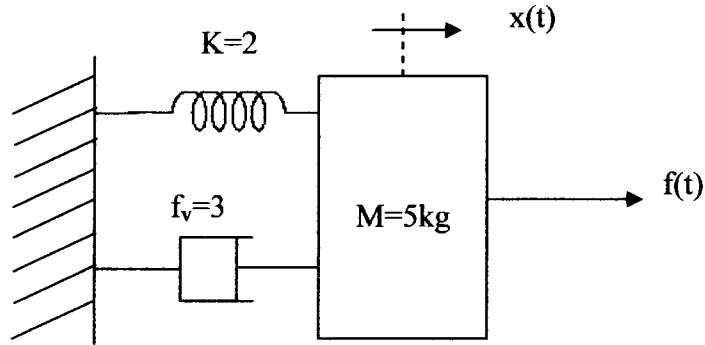

**FIGURE Q2(c)**

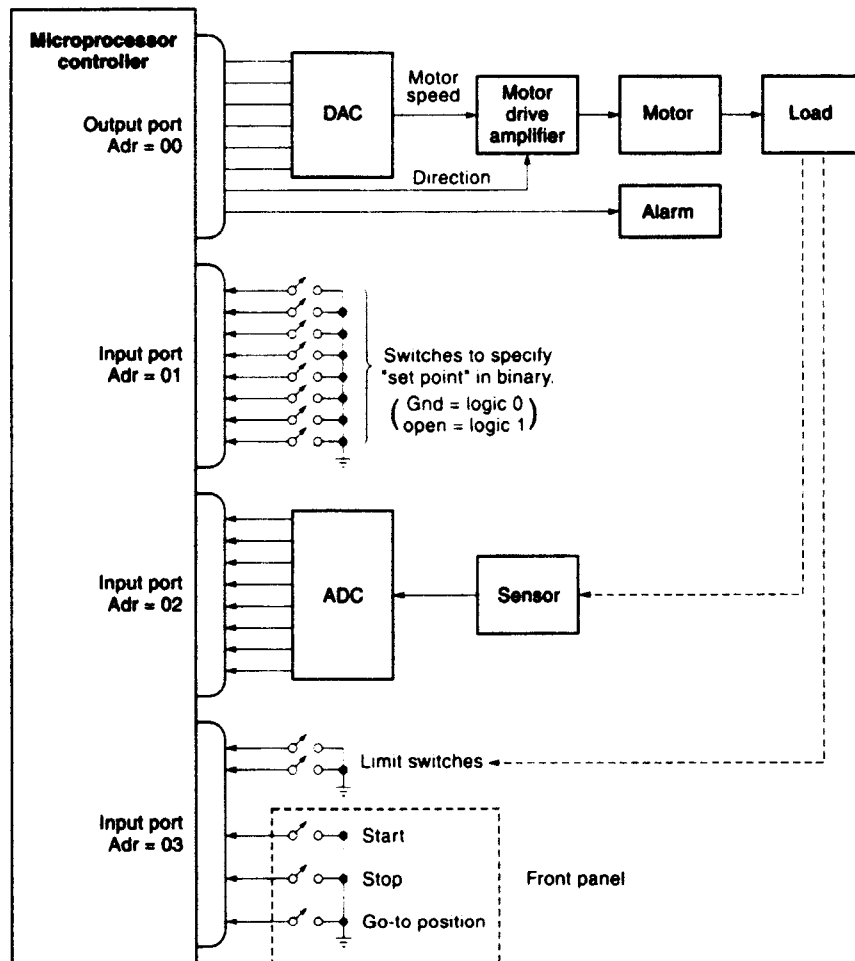

**FIGURE Q5(d)**

**FINAL EXAM**

SEMESTER/ SESSION : SEM II / 2012/2013  
 COURSE : CONTROL SYSTEM

PROGRAMME : 3 DAE / DAL  
 COURSE CODE : DAE 32103

**Table 2: Laplace Transform Theorem**

Item no.	Theorem	Name
1.	$\mathcal{L}[f(t)] = F(s) = \int_{0^-}^{\infty} f(t)e^{-st} dt$	Definition
2.	$\mathcal{L}[kf(t)] = kF(s)$	Linearity theorem
3.	$\mathcal{L}[f_1(t) + f_2(t)] = F_1(s) + F_2(s)$	Linearity theorem
4.	$\mathcal{L}[e^{-at}f(t)] = F(s + a)$	Frequency shift theorem
5.	$\mathcal{L}[f(t - T)] = e^{-sT}F(s)$	Time shift theorem
6.	$\mathcal{L}[f(at)] = \frac{1}{a}F\left(\frac{s}{a}\right)$	Scaling theorem
7.	$\mathcal{L}\left[\frac{df}{dt}\right] = sF(s) - f(0^-)$	Differentiation theorem
8.	$\mathcal{L}\left[\frac{d^2f}{dt^2}\right] = s^2F(s) - sf(0^-) - f'(0^-)$	Differentiation theorem
9.	$\mathcal{L}\left[\frac{d^nf}{dt^n}\right] = s^nF(s) - \sum_{k=1}^n s^{n-k}f^{(k-1)}(0^-)$	Differentiation theorem
10.	$\mathcal{L}\left[\int_{0^-}^t f(\tau) d\tau\right] = \frac{F(s)}{s}$	Integration theorem
11.	$f(\infty) = \lim_{s \rightarrow 0} sF(s)$	Final value theorem <sup>1</sup>
12.	$f(0^+) = \lim_{s \rightarrow \infty} sF(s)$	Initial value theorem <sup>2</sup>

<sup>1</sup> For this theorem to yield correct finite results, all roots of the denominator of  $F(s)$  must have negative real parts and no more than one can be at the origin.

<sup>2</sup> For this theorem to be valid,  $f(t)$  must be continuous or have a step discontinuity at  $t = 0$  (i.e., no impulses or their derivatives at  $t = 0$ ).

**FINAL EXAM**

SEMESTER/ SESSION : SEM II / 2012/2013  
 COURSE : CONTROL SYSTEM

PROGRAMME : 3 DAE / DAL  
 COURSE CODE : DAE 32103

**Table 3: Mathematical Model of Translational Mechanical Element**

Component	Force-velocity	Force-displacement	Impedance $Z_u(s) = F(s) X(s)$
<p>Spring</p> <p><math>K</math></p>	$f(t) = K \int_0^t v(\tau) d\tau$	$f(t) = Kx(t)$	$K$
<p>Viscous damper</p> <p><math>f_v</math></p>	$f(t) = f_v v(t)$	$f(t) = f_v \frac{dx(t)}{dt}$	$f_v s$
<p>Mass</p> <p><math>M</math></p>	$f(t) = M \frac{dv(t)}{dt}$	$f(t) = M \frac{d^2x(t)}{dt^2}$	$Ms^2$

**Table 4 : Formula**

<p>Rise time,</p> $t_r = \frac{\pi - \cos^{-1} \zeta}{\omega_n \sqrt{1 - \zeta^2}}$	<p>Peak time,</p> $t_p = \frac{\pi}{\omega_n \sqrt{1 - \zeta^2}}$
<p>Percentage overshoot,</p> $\%M_p = e^{\frac{-\zeta\pi}{\sqrt{1-\zeta^2}}}$	<p>Settling time,</p> $t_s = \frac{4}{\zeta\omega_n} \text{ (2\% criterion)}$ $t_s = \frac{3}{\zeta\omega_n} \text{ (5\% criterion)}$

**FINAL EXAM**

SEMESTER/ SESSION : SEM II / 2012/2013  
 COURSE : CONTROL SYSTEM

PROGRAMME : 3 DAE / DAL  
 COURSE CODE : DAE 32103

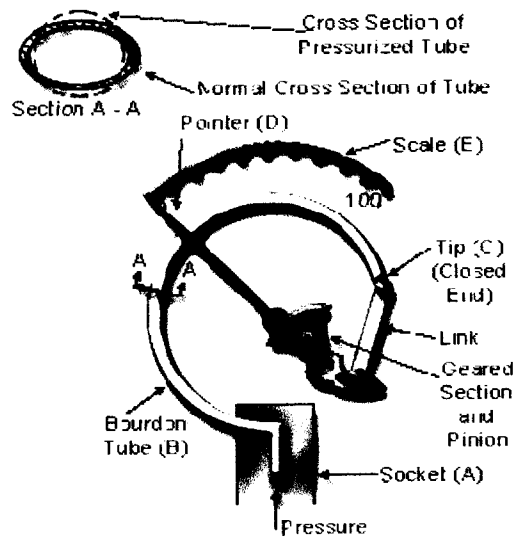

**FIGURE Q6(d)**

**Table1: Laplace Transform Table**

Item no.	$f(t)$	$F(s)$
1.	$\delta(t)$	1
2.	$u(t)$	$\frac{1}{s}$
3.	$tu(t)$	$\frac{1}{s^2}$
4.	$t^n u(t)$	$\frac{n!}{s^{n+1}}$
5.	$e^{-at}u(t)$	$\frac{1}{s+a}$
6.	$\sin \omega t u(t)$	$\frac{\omega}{s^2 + \omega^2}$
7.	$\cos \omega t u(t)$	$\frac{s}{s^2 + \omega^2}$