



UNIVERSITI TUN HUSSEIN ONN MALAYSIA

**FINAL EXAMINATION
SEMESTER I
SESSION 2012/2013**

COURSE NAME : CIRCUIT THEORY
COURSE CODE : DEE 1223 / DAE 11103
PROGRAMME : 1 DEE
EXAMINATION DATE : OCTOBER 2012
DURATION : 3 HOURS
INSTRUCTION : ANSWER FIVE (5) QUESTIONS ONLY.

THIS QUESTION PAPER CONSISTS OF TEN (10) PAGES

- Q1** (a) In Figure Q1(a), determine the quantity (voltage, current, or resistance) that is being measured and its value for each of the following specified switch settings on a typical analog multimeter.
- (i) DC volts: 60
 - (ii) DC mA: 12
 - (iii) OHMS: x1K
- (6 marks)
- (b) The I-V characteristics of a light bulb are provided in Figure Q1(b). Note the nonlinearity of the curve, indicating a wide range in resistance of the bulb with applied voltage. If the rated DC voltage is 120 V, find the wattage rating of the bulb. Also calculate the resistance of the bulb under rated conditions.
- (6 marks)
- (c) Using the information provided in Figure Q1(c), find the branch resistors R_1 and R_3 , the total resistance R_T , and the voltage source E .
- (8 marks)
- Q2** (a) Use nodal analysis to find v_1 , v_2 , and i_1 for the circuit shown in Figure Q2(a).
- (10 marks)
- (b) Calculate the mesh currents i_1 and i_2 in Figure Q2(b) and determine the power dissipated in the 8Ω resistor.
- (10 marks)
- Q3** (a) State the maximum power transfer theorem.
- (2 marks)
- (b) When is maximum power delivered from a source to a load?
- (2 marks)
- (c) The variable resistor in the circuit in Figure Q3(c) is adjusted for maximum power transfer to R_o .
- (i) Find the value of R_o .

- (ii) Find the maximum power that can be delivered to R_o .

(8 marks)

- (d) In superposition theorem, the presence of three sources results in three different networks to be analysed. Find the current I_1 of the network in Figure Q3(d).

(8 marks)

- Q4** (a) Find the equivalent capacitance for the circuit shown in Figure Q4(a).

(4 marks)

- (b) Determine the voltage across the capacitors in the circuit of Figure Q4(b) under DC conditions.

(8 marks)

- (c) The current through a 12 mH inductor is known to be

$$i_L = 4 \sin 100t \text{ A} \quad t > 0$$

- (i) Find the voltage across the inductor for $t > 0$

- (ii) Find the energy stored in the inductor at $t = \frac{\pi}{200} \text{ s}$

(8 marks)

- Q5** (a) Find the time constant of the circuit shown in Figure Q5(a).

(4 marks)

- (b) In the circuit in Figure Q5(b), the voltage and current expressions are

$$\begin{aligned} v &= 100e^{-1000t} \text{ V}, \quad t \geq 0 \\ i &= 5e^{-1000t} \text{ mA}, \quad t \geq 0^+ \end{aligned}$$

Find :

- (i) R
(ii) C
(iii) τ (in milliseconds)

(iv) the initial energy stored in the capacitor

(8 marks)

(c) Consider the circuit shown in Figure Q5(c). Assume that the switch has been closed for a very long time prior to $t = 0$. Find expressions for $i(t)$ and $v(t)$.

(8 marks)

Q6 (a) In a linear circuit, the voltage source is $v_s = 12 \sin (10^3 t + 24^\circ)$ V.

- (i) What is the angular frequency of the voltage?
- (ii) What is the frequency of the source?
- (iii) Find the period of the voltage.
- (iv) Express v_s in cosine form.
- (v) Determine v_s at $t = 2.5$ ms.

(10 marks)

(b) For the circuit shown in Figure Q6(b) :

- (i) Find the total impedance Z_T .
- (ii) Determine the current I_S .
- (iii) Calculate V_R and V_C .
- (iv) Find I_C

(10 marks)

Q7 (a) The voltage across a load is $v(t) = 160 \cos 377t$ V and the current through the element in the direction of the voltage drop is $i(t) = 4 \cos (377t + 45^\circ)$ A. Find :

- (i) complex power
- (ii) apparent power
- (iii) real / average power
- (iv) reactive power
- (v) power factor and specify whether it is leading or lagging

(10 marks)

(b) A 50 kW load operates from a 60 Hz, 10 kV_{rms} line with a power factor of 60% lagging. Compute the capacitance that must be placed in parallel with the load to achieve a 90% lagging power factor.

(10 marks)

FINAL EXAMINATION

SEMESTER / SESSION : SEMESTER I/ 2012/2013
COURSE : CIRCUIT THEORY

PROGRAMME : 1 DEE/DET/DAE
COURSE CODE : DEE1223 / DAE11103

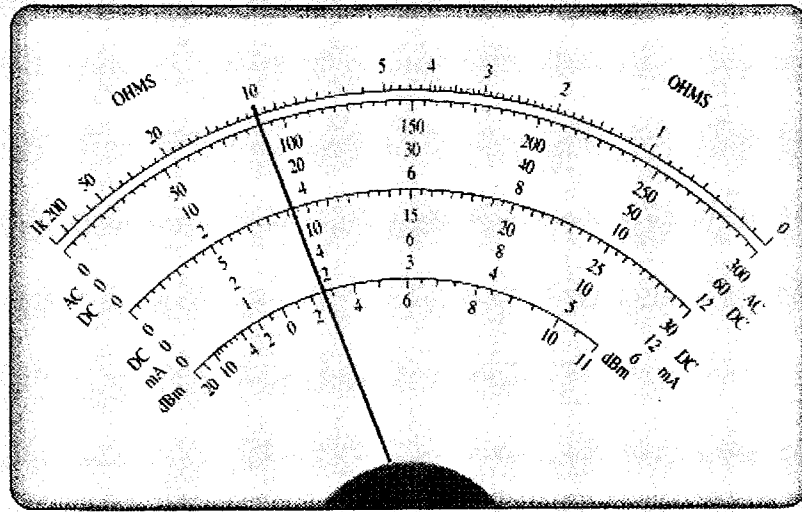

FIGURE Q1(a)

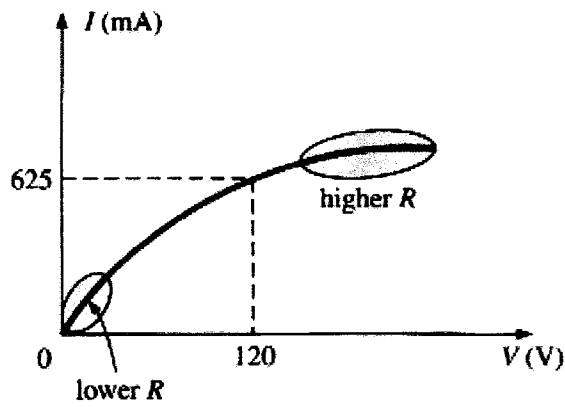

FIGURE Q1(b)

FINAL EXAMINATION

SEMESTER / SESSION : SEMESTER I/ 2012/2013
 COURSE : CIRCUIT THEORY

PROGRAMME : 1 DEE/DET/DAE
 COURSE CODE : DEE1223 / DAE11103

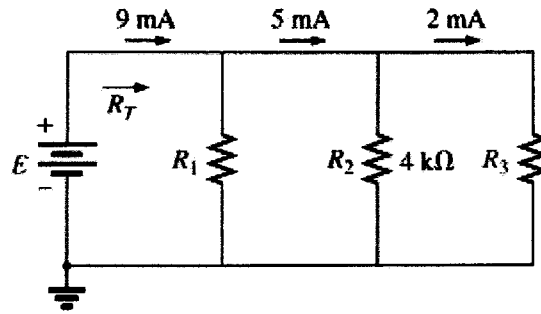

FIGURE Q1(c)

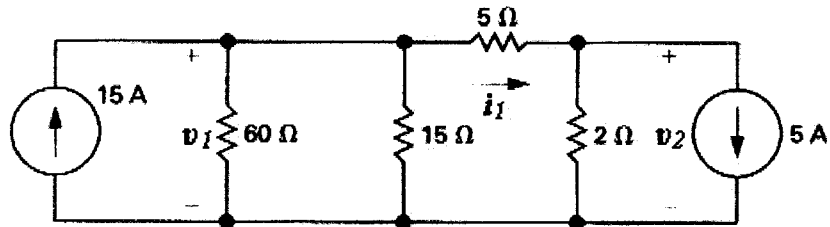

FIGURE Q2(a)

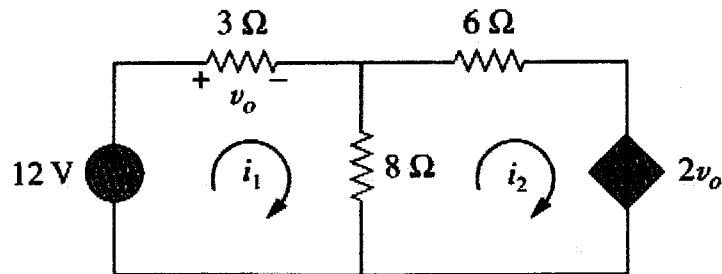

FIGURE Q2(b)

FINAL EXAMINATION

SEMESTER / SESSION : SEMESTER I / 2012/2013
 COURSE : CIRCUIT THEORY

PROGRAMME : 1 DEE/DET/DAE
 COURSE CODE : DEE1223 / DAE11103

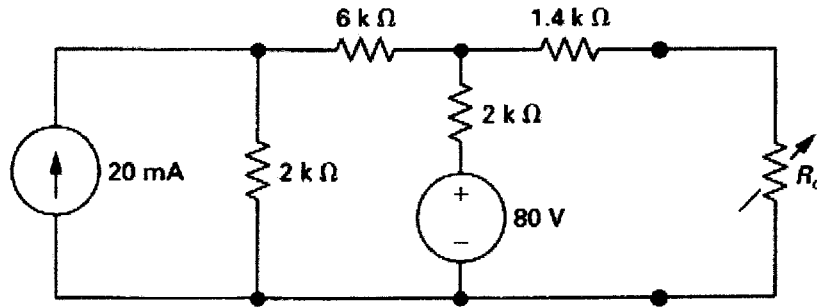

FIGURE Q3(c)

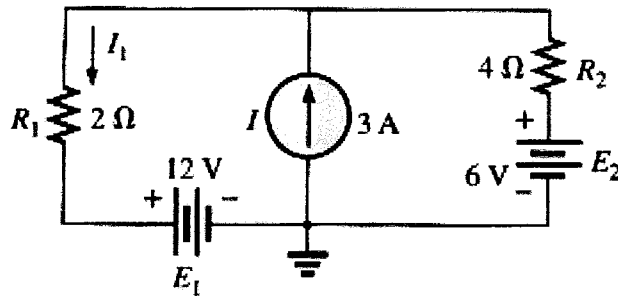

FIGURE Q3(d)

FINAL EXAMINATION

SEMESTER / SESSION : SEMESTER I / 2012/2013
 COURSE : CIRCUIT THEORY

PROGRAMME : 1 DEE/DET/DAE
 COURSE CODE : DEE1223 / DAE11103

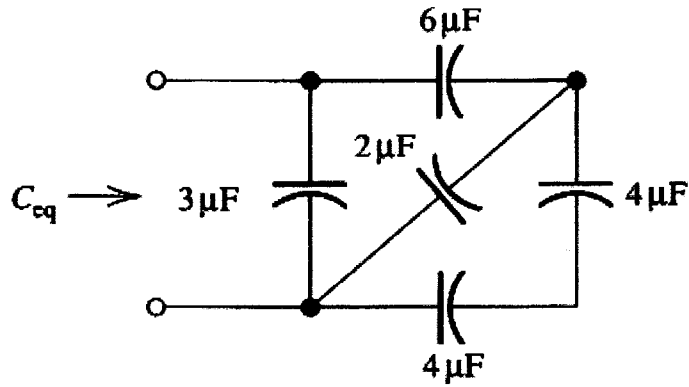

FIGURE Q4(a)

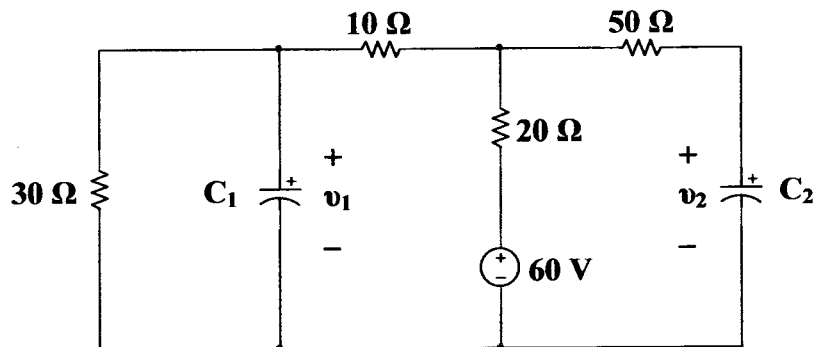

FIGURE Q4(b)

FINAL EXAMINATION

SEMESTER / SESSION : SEMESTER I / 2012/2013
 COURSE : CIRCUIT THEORY

PROGRAMME : 1 DEE/DET/DAE
 COURSE CODE : DEE1223 / DAE11103

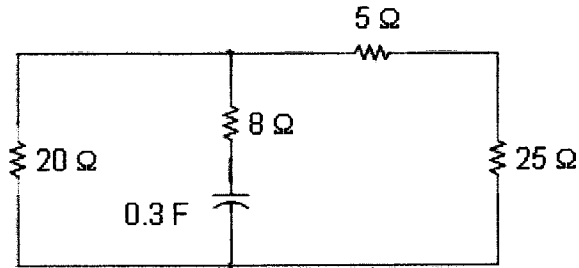

FIGURE Q5(a)

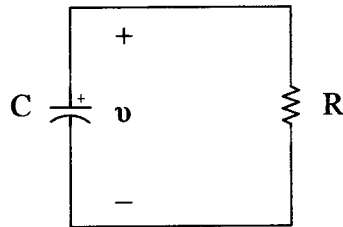

FIGURE Q5(b)

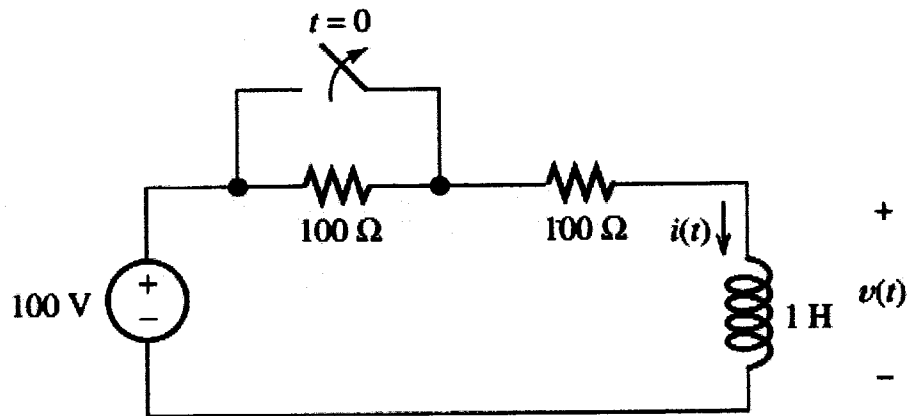

FIGURE Q5(c)

FINAL EXAMINATION

SEMESTER / SESSION : SEMESTER I / 2012/2013
 COURSE : CIRCUIT THEORY

PROGRAMME : 1 DEE/DET/DAE
 COURSE CODE : DEE1223 / DAE11103

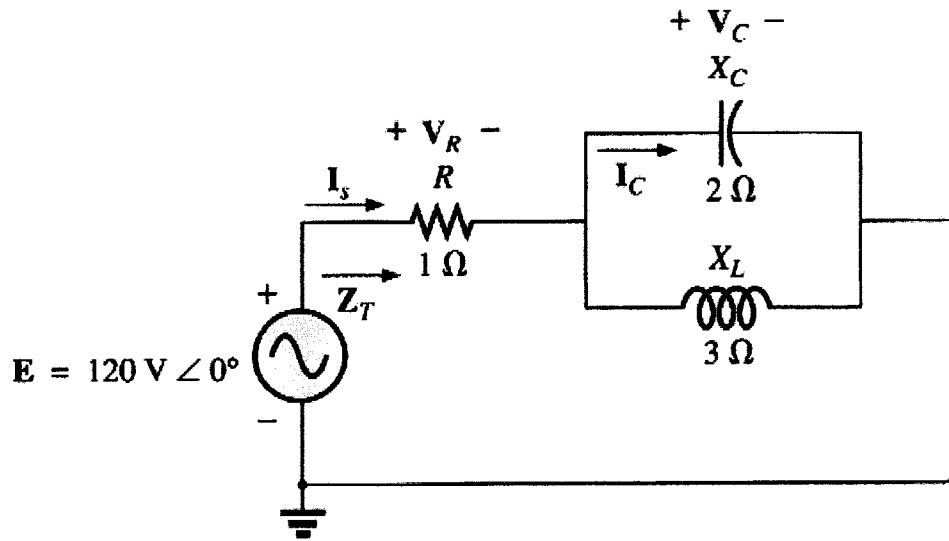

FIGURE Q6(b)