



UNIVERSITI TUN HUSSEIN ONN MALAYSIA

**FINAL EXAMINATION
SEMESTER II
SESSION 2012/2013**

- COURSE NAME** : TECHNICAL COMMUNICATION 1
- COURSE CODE** : UWB 10402
- PROGRAMME** : 1 DAA/DAB/DAE/DAJ/DAM/DAT/DAU
2 DAA/DAE
3 DAI/DAM
- EXAMINATION DATE** : MARCH 2013
- DURATION** : 2 HOURS
- INSTRUCTIONS** : A) ANSWER **ALL** QUESTIONS
- B) ANSWER **ALL** QUESTIONS IN THE
ANSWER BOOKLET PROVIDED
- C) YOU ARE **NOT** ALLOWED TO TAKE
THE QUESTION PAPER OUT OF THE
EXAMINATION HALL

THIS QUESTION PAPER CONSISTS OF **FOUR (4)** PAGES

Q1 Form questions based on the given answers.

(a) Question: _____

Answer: *I have been studying in UTHM for two semesters.*

(b) Question: _____

Answer: *The Physics experiment that I am working on is time consuming.*

(c) Question: _____

Answer: *I strongly disagree on the ban of Facebook in the university campus.*

(d) Question: _____

Answer: *Because students cannot manage their time effectively.*

(e) Question: _____

Answer: *I prefer face-to-face consultation with the lecturer rather than e-mail correspondence.*

(10 marks)

Q2 Provide formal definition for each of the following terms in **NOT MORE** than 20 words:

- (a) Calculator
- (b) Thunderstorm
- (c) Asthma
- (d) Escalator
- (e) Tsunami

(15 marks)

Q3 Figure 1 shows a printer. Choose only 6 parts of the object and write the technical description of each part. Include physical and functional aspects of each part and also the introduction and conclusion in the description. You may add other relevant information but your description **MUST NOT BE MORE** than 250 words.

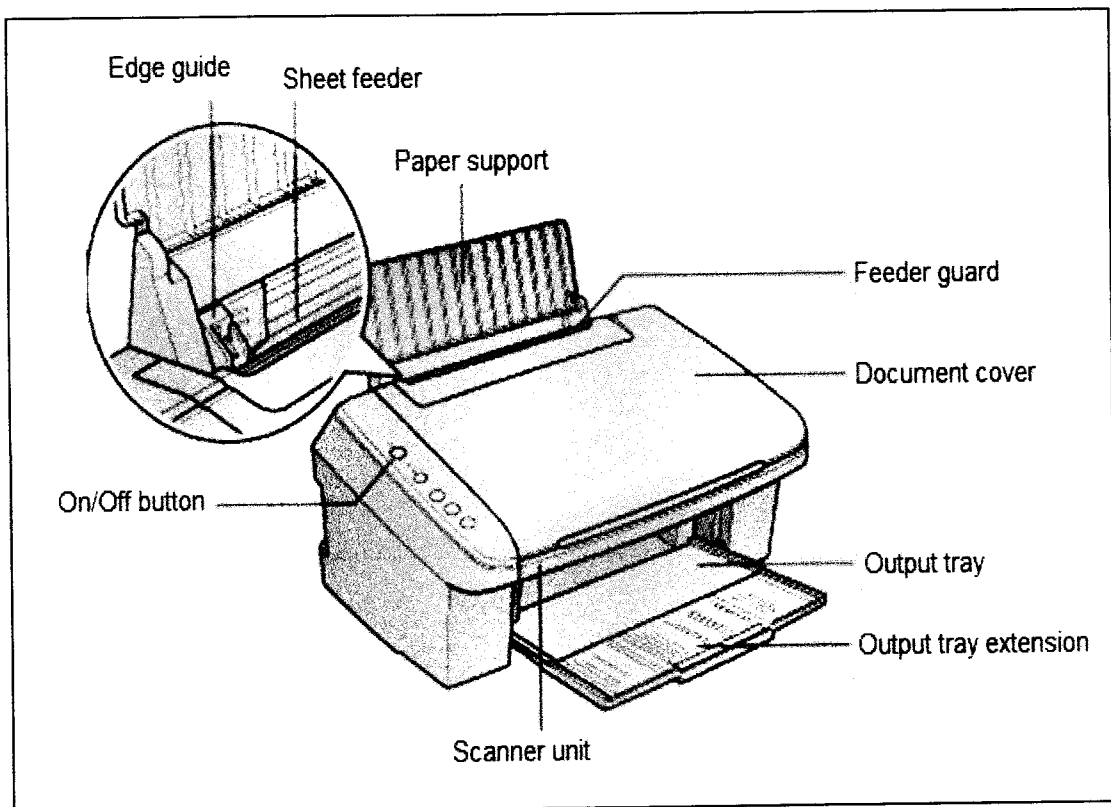

Figure 1: Printer

(25 marks)

- Q4** You are working for a computer company in Batu Pahat. You received a complaint from a customer that the monitor of the computer could only display half of the entire screen. After your inspection, you discovered that the monitor of the computer was faulty but it is still under warranty.

Write an inspection report to the company.

Your report should include:

- (a) Introduction
- (b) Objectives
- (c) Methods
- (d) Results/Findings
- (e) Conclusion

(50 marks)

- END OF QUESTIONS -