

CONFIDENTIAL



UNIVERSITI TUN HUSSEIN ONN MALAYSIA

**FINAL EXAMINATION
SEMESTER 2
SESSION 2014/2015**

COURSE NAME : THERMODYNAMICS I
COURSE CODE : BDA20202
PROGRAMME : BDD
EXAMINATION DATE : JUNE / JULY2015
DURATION : 2 HOURS 30 MINUTES
INSTRUCTION : PART A: ANSWER THREE (3) FROM FIVE (5) QUESTIONS, AND
PART B: ANSWER ALL QUESTIONS

THIS QUESTION PAPER CONSISTS OF FIVE (5) PAGES

CONFIDENTIAL

PART A

Q1 (a) With the assistance of a diagram, define the following terms:

- (i) gauge pressure,
- (ii) vacuum pressure, and
- (iii) absolute pressure.

(5 marks)

(b) A hydraulic lift as shown in **FIGURE Q1(b)** is to be used to lift a 2500 kg weight by putting a weight of 25 kg on a piston with a diameter of 10 cm. Determine the diameter of the piston on which the weight is to be placed.

(10 marks)

(c) Two phases fluid inside a tank as shown in **FIGURE Q1(c)** are well mixed between saturated liquid and saturated vapour, forming a homogeneous mixture with average properties. If the volume occupied by saturated liquid is V_f , and the volume occupied by saturated vapour is V_g . The total volume, V is the sum of the two:

$$V = V_f + V_g$$

From the above equation, **derive** that the average specific volume, v_{avg} is equal to:

$$v_{avg} = v_f + x \cdot v_{fg}$$

Where;

x is a ratio of the vapor mass to the total mass of the fluid, and

$$v_{fg} = v_g - v_f$$

(5 marks)

Q2 (a) Liquid water inside a closed cylinder is being compressed until its temperature rises to 35°C.

- (i) Explain whether this information is sufficient to determine the internal energy of water.
- (ii) Show the value and the appropriate steps to determine this property.

(5 marks)

(b) A polytropic process is defined as $PV^n = C$, where n is polytropic index and C is a constants. Derive the equation for a boundary work of an ideal gas undergoing a polytropic process at isothermal condition.

(5 marks)

- (c) Air with mass of 2.4 kg at 150 kPa and 120°C is contained in a frictionless piston–cylinder device. The air is now compressed to a final pressure of 600 kPa. During the process, heat is allowed to transfer from the air inside the cylinder to the surrounding so that the temperature inside the cylinder remains constant. Calculate the work input during this process. (10 marks)
- Q3** (a) A fixed mass of air behaving like an ideal gas is being heated from 50°C to 80°C at two conditions, that is, at constant volume and at constant pressure.
- (i) Which condition do you think the energy required will be greater?
(ii) Give reason for your answer, and
(iii) support your answer with the sketches of both systems. (5 marks)
- (b) A piston–cylinder device contains 5 kg of refrigerant-134a at 800 kPa and 70°C. The refrigerant is now cooled at constant pressure until it exists as a liquid at 15°C. Determine the amount of heat loss and show the process on a T - v diagram with respect to saturation lines. (15 marks)
- Q4** (a) A ventilating fan of a chemical laboratory in Universiti Tun Hussein Onn Malaysia has a volume flow rate of 50 L/s and run continuously. If the density of air inside the laboratory is 1.40 kg/m³, determine the mass of air vented out of the laboratory in one day. (5 marks)
- (b) Air enters a 30 cm diameter pipe steadily at 200 kPa and 20°C with velocity of 300 meter in a minute. Air is heated as it flows, and leaves the pipe at 150 kPa and 35°C. Determine:
- (i) the volume flow rate of air at the inlet,
(ii) the mass flow rate of air, and
(iii) the velocity and volume flow rate at the exit. (15 marks)
- Q5** (a) Heat pumps and refrigerators (or air conditioning systems) are two systems that utilize a common thermodynamics cycle consisting of four main components. Sketch both systems and explain the differences between them. (5 marks)

- (b) Refrigerant 134a enters a condenser of a residential heat pump at 800 kPa, 35°C and at a rate of 0.018 kg/s. It leaves the condenser at 800 kPa as saturated liquid. If the compressor consumes 1.2 kW of power, determine;
- (i) the rate of heat rejection from the condenser,
 - (ii) the COP of the heat pumps,
 - (iii) the rate of heat absorption from the outside air, and
 - (iv) sketch the schematic diagram for heat pump system (include W_{in} , Q_H and Q_L).

(15 marks)

PART B

- Q6** (a) On a temperature versus entropy ($T-s$) diagram, does the actual exit state of an adiabatic turbine has to be on right-hand side or left-hand side of its isentropic exit state? Why?
- (b) Helium gas is compressed from 90 kPa and 30°C to 450 kPa in a reversible-adiabatic process. Determine the final temperature and the work done, assume that the process take place in;
- (i) a piston cylinder device, and
 - (ii) a steady flow compressor.

(3 marks)

(17 marks)

– END OF QUESTION –

FINAL EXAMINATION

SEMESTER/SESSION: SEM 2 / 2014-2015
 COURSE : THERMODYNAMICS I

PROGRAMME : BDD
 COURSE CODE : BDA 20202

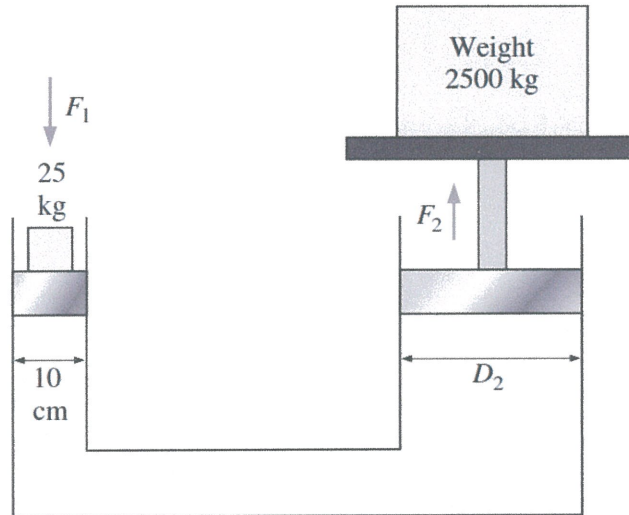

FIGURE Q1(b)

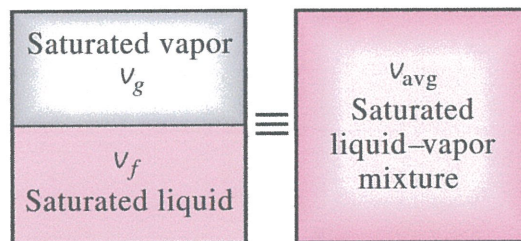

FIGURE Q1(c)