



UNIVERSITI TUN HUSSEIN ONN MALAYSIA

FINAL EXAMINATION SEMESTER II SESSION 2012/2013

COURSE NAME : VIBRATION & NOISE
COURSE CODE : BDA 40603 / BDC 4013
PROGRAMME : 4 BDD
EXAMINATION DATE : JUNE 2013
DURATION : 3 HOURS
INSTRUCTIONS : ANSWER **TWO (2)** QUESTIONS
FROM **PART A** AND **TWO (2)**
QUESTIONS FROM **PART B**

THIS PAPER CONTAINS TEN (10) PAGES INCLUDING COVER PAGE

PART A: ANSWER TWO (2) QUESTIONS ONLY

- Q1 (a)** Sketch the amplitude versus time graph comparison of motion for different types of damping. Also specify the damping coefficient, ξ value for each motion. (5 marks)
- (b) FIGURE Q1** shows a system of two masses attached to tightly stretched string, fixed at both end. The value for $m_1 = m_2 = 2$ kg and $k_1 = k_2 = k_3 = 8$ N/m. Assume the system undergoes cosine harmonic motion.
- (i) Determine the natural frequency of the system (5 marks)
- (ii) Find the mode shape of the system (6 marks)
- (iii) Produce the free body vibration equation of m_1 and m_2 for the following initial condition
1. $x_1(0) = 1, x_2(0) = 0, \dot{x}_1(0) = 0 \ \& \ \dot{x}_2(0) = 1$
 2. $x_1(0) = 1, x_2(0) = 0, \dot{x}_1(0) = 0 \ \& \ \dot{x}_2(0) = 0$
- (9 marks)

- Q2 (a)** Explain briefly;
- (i) Dunkerly's Formula
 - (ii) Rayleigh's Method
 - (iii) Holzer's Method
 - (iv) Matrix Iteration

(8 marks)

- (b) **FIGURE Q2(b)** shows an overhead crane used for in heavy-duty jobs. The trolley has weights ten times the weight of the girder. Estimate the fundamental frequency of the system by using Dunkerley's Formula.

Useful equation:

$$k = \frac{48EI}{l^3}$$

(7 marks)

- (c) **FIGURE Q2(c)** shows three degree of freedom spring-mass system.

- (i) Calculate the fundamental natural frequency of vibration of system by using Rayleigh's Method. Assume that $m_1 = m_2 = m_3 = m$, $k_1 = k_2 = k_3 = k$. Use the mode of the system as;

$$\bar{X} = \begin{Bmatrix} 1 \\ 2 \\ 3 \end{Bmatrix}$$

- (ii) If the exact value of $\omega_1 = 0.4450 \sqrt{\frac{k}{m}}$, find the exact value of fundamental mode shape $\vec{X}^{(1)}$.

Useful equation;

$$\begin{bmatrix} 4.0489 & -1.0 & -1.0 \\ -1.0 & 3.0489 & -2.0 \\ -1.0 & -2.0 & 2.0489 \end{bmatrix} \begin{Bmatrix} X_1^{(1)} \\ X_2^{(1)} \\ X_3^{(1)} \end{Bmatrix} = \begin{Bmatrix} 0 \\ 0 \\ 0 \end{Bmatrix}$$

$$X_2^{(1)} + X_3^{(1)} = 4.0489X_1^{(1)}$$

(10 marks)

- Q3 (a)**
- (i) Determine the meaning of active and passive vibration isolator (3 marks)
- (ii) Explain the fixed bases and moving based type of vibration isolation condition (3 marks)
- (iii) State the function of dynamic vibration absorber. (2marks)
- (b) A sensitive electronic system, of mass 30 kg, is supported by a spring damper system on the floor of a building that is subject to a harmonic motion in the frequency range 10 – 75 Hz. If damping ratio of the suspension is 0.25;
- (i) Determine the stiffness of suspension if the amplitude of vibration transmitted to the system is to be less than 15 % of the floor vibration over the given frequency. (10 marks)
- (ii) Analyze the acceptable amount of force a transmissibility for the minimum and maximum stiffness values produced in (i) (7 marks)

Useful equation

$$\frac{X}{Y} = T_r = \left\{ \frac{1 + (2\xi r)^2}{(1 - r^2)^2 + (2\xi r)^2} \right\}^{\frac{1}{2}}$$

$$r = \frac{\omega}{\omega_n}; \quad \omega_n = \sqrt{\frac{k}{m}}$$

PART B: ANSWER TWO(2) QUESTIONS ONLY

- Q4 (a)** Define the meaning of reverberation room and anechoic room. Illustrate your answer with diagram or picture

(6 marks)

- (b) The noise level at a site on which it is proposed to build a housing estate arises mainly from trains on a nearby railways line. There are three types of train using the line which are fast express trains, slower suburban trains and freight trains. It is proposed to predict the equivalent continuous noise level at the site over a 24 hours period from sample noise measurement of each of the three noise events. The results of these measurement are:

For fast trains, $L_{eq} = 85$ dB(A) over a period of 12 seconds

For slow trains, $L_{eq} = 78$ dB(A) over a period of 18 seconds

For freight trains, $L_{eq} = 76$ dB(A) over a period of 24 seconds

During the 24 hours period there are 120 fast trains, 200 slow trains and 80 freight trains. Calculate the equivalent continuous noise level over a 24 hours period.

(11 marks)

- (c) A compressor with an A-weighted sound power level (SWL) of 140 dB is radiating uniformly over a flat non-absorbent surface (hemispherical radiation). Calculate the sound pressure level (SPL) at a distance of:

- (i) 10 meter
(ii) 45 meter

(8 marks)

Q5 (a) Briefly explain the meaning of these term;

- (i) Reflection
- (ii) Refraction
- (iii) Diffraction
- (iv) Interference

(4 marks)

(b) From **Q5(a)(i)** and **Q5(a)(ii)**, discuss the effect might play in the environment noise produced by an open-air auditorium.

(6 marks)

(c) NC 40 has been set down as the limiting value in a contract for designing and installing an air conditioning system in a building, however measured spectrum is that show on **FIGURE Q5**.

(i) Find the NC value after measured by referring the spectrum in **FIGURE Q5** and explain.

(5 marks)

(ii) Calculate the reduction of dB that should be made to achieve the NC40 to make the building is in a comfort environment.

(5 marks)

(iii) Explain in detail **TWO (2)** improvement suggestions to get the NC40.

(5 marks)

- Q6 (a) (i) Explain distinguish between **noise control at source** and **noise control in the transmission path**. Illustrate your answer with appropriate example. (6 marks)**
- (ii) From your answer in Q6 (i), which is preferable and explain why (8 marks)**
- (b) The dimensions of a conference room are 8 m x 5 m x 3 m high. The floor is carpeted and the walls are made of concrete block work with a plaster finish. The room has three windows, each with dimensions 1.5 m x 1.0 m. The ceiling is made of plasterboard, and the door, of dimensions 2 m x 1.0 m, is of solid hardwood. Using Sabine's equation, calculate;**
- (i) the reverberation time at 1kHz of empty room, (5 marks)**
- (ii) when occupied by 10 directors, and (3 marks)**
- (iii) The company secretary during board meetings. (3 marks)**

Use absorption coefficient (α) in **TABLE Q6**.

FINAL EXAMINATION

SEMESTER / SESSION	: SEMESTER II / 2012/13	PROGRAMME	: 4 BDD
COURSE	: VIBRATION& NOISE	COURSE CODE	: BDA 40603 / BDC 4013

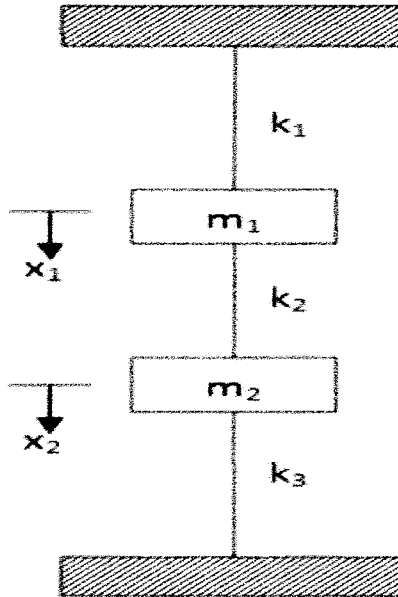

FIGURE Q1

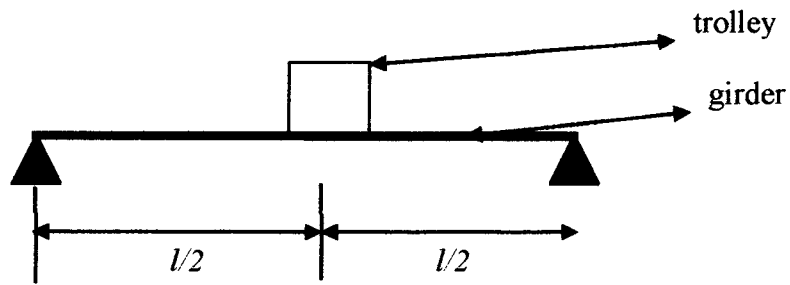

FIGURE Q2(b)

FINAL EXAMINATION

SEMESTER / SESSION	: SEMESTER II / 2012/13	PROGRAMME	: 4 BDD
COURSE	: VIBRATION & NOISE	COURSE CODE	: BDA 40603 / BDC 4013

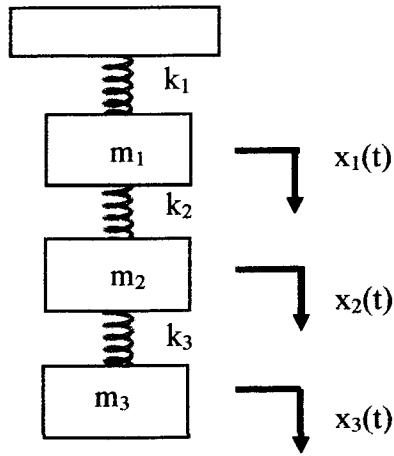

FIGURE Q2(c)

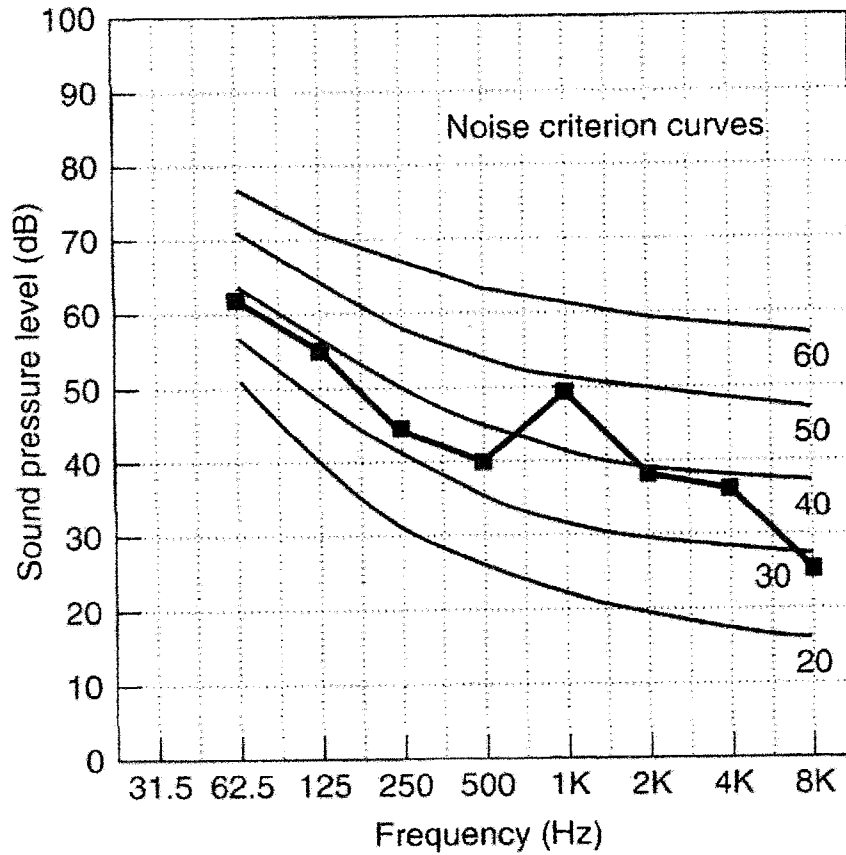

FIGURE Q5

FINAL EXAMINATION

SEMESTER / SESSION	:	SEMESTER II / 2012/13	PROGRAMME	:	4 BDD
COURSE	:	VIBRATION& NOISE	COURSE CODE	:	BDA 40603 / BDC 4013

	α
Absortion area per person	0.45
plasterboard	0.08
hardwood	0.07
glazing	0.05
Plaster on concrete blockwork	0.05
carpeting	0.64

TABLE Q6