



UNIVERSITI TUN HUSSEIN ONN MALAYSIA

**FINAL EXAMINATION
SEMESTER I
SESSION 2018/2019**

COURSE NAME : PACKAGING SYSTEM
DEVELOPMENT

COURSE CODE : BNK 40803

PROGRAMME CODE : BNK

EXAMINATION DATE : DECEMBER 2018 / JANUARY 2019

DURATION : 3 HOURS

INSTRUCTION : ANSWERS ALL QUESTIONS

TERBUKA

THIS QUESTION PAPER CONSISTS OF FIVE (5) PAGES

CONFIDENTIAL

Q1 Figure Q1 shows a new idea to develop container 20 Oz Aluminum water bottle before launching in the market. Using the concept of packaging development, develop the product based on the elements below:

- (a) Planning development process activities (4 marks)
- (b) Structure of package development process (6 marks)
- (c) Activities in the total product development process (15 marks)

Q2 (a) Describe the relation between package design and package system in product development. (3 marks)

(b) “One of the keys to packaging design success is the preparation of an accurate brief”. From that statement, propose the packaging design brief. (10 marks)

(c) Analyze the marketing responsibilities of package design in the development of the product. (12 marks)

Q3 (a) Differentiate between specification, packaging material specification and packing specification. (3 marks)

(b) **Figure Q3(b)** shows the presentation of the sheet specification of the 20 ml HDPE bottle components for BNK company. Based on the figure, outline a simple of the specification form. The form must have the following elements:

- (i) Scope
- (ii) Construction
- (iii) Product protection
- (iv) Consumer function
- (v) Graphics

TERBUKA

(22 marks)

CONFIDENTIAL

- Q4** (a) Discover **SEVEN(7)** elements of Packaging System Development Costs.
(14 marks)
- (b) Based on the Packaging Regulation in USA, select with explanation **THREE (3)** packaging regulations that can be implemented in our country.
(11 marks)

- END OF QUESTION -

TERBUKA

FINAL EXAMINATION

SEMESTER/ SESSION : SEM I/ 2018/2019
COURSE : PACKAGING SYSTEM DEVELOPMENT

PROGRAMME CODE : BNK
COURSE CODE : BNK 40803

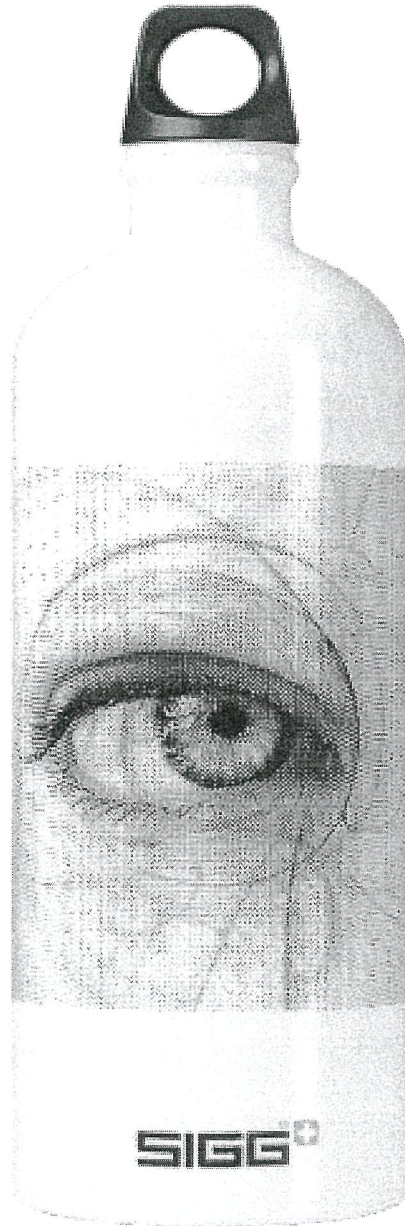

TERBUKA

Figure Q1

CONFIDENTIAL

FINAL EXAMINATION

SEMESTER/ SESSION : SEM I/ 2018/2019
 COURSE : PACKAGING SYSTEM DEVELOPMENT

PROGRAMME CODE : BNK
 COURSE CODE : BNK 40803

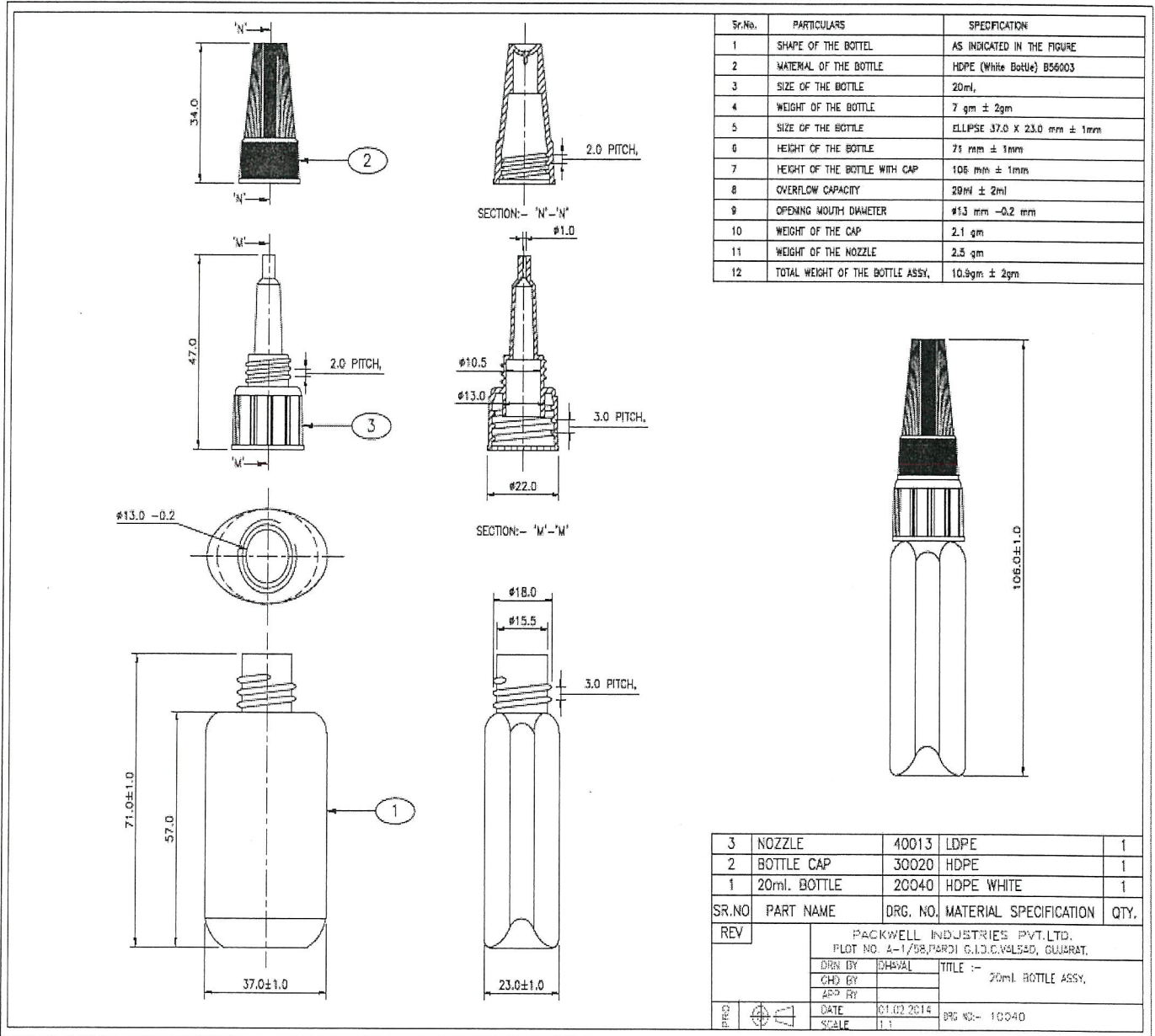

Figure Q3(b)

TERBUKA

CONFIDENTIAL