

UNIVERSITI TUN HUSSEIN ONN MALAYSIA

FINAL EXAMINATION SEMESTER I SESSION 2010/2011

COURSE NAME : POWER TRAIN AND AXLES
COURSE CODE : DDE 2043
PROGRAMME : 3 DDT
EXAMINATION DATE : NOVEMBER/DECEMBER 2010
DURATION : 2 1/2 HOURS
INSTRUCTIONS : ANSWER **FOUR (4)**
QUESTIONS ONLY

THIS QUESTION PAPER CONSISTS OF TEN (10) PAGES

- Q1**
- (a) State why flexible clutch disc is different than a rigid disc. (3 marks)
 - (b) Explain three main functions of master cylinder in the hydraulic clutch linkage system (8 marks)
 - (c) Explain why dual mass flywheel is better than single mass flywheel (6 marks)
 - (d) Describe how to determine which of the following cause of a noise; pilot bearing, throwout bearing and lack of lubrication at fork and pivot. (8 marks)

- Q2**
- (a) The basic operation of planetary gear set in automatic transmission can be represented by law of planetary gear action. The law can be summarized in the table below. Since the table is uncompleted, fill in the blanks inside the table (represent by number 1 to 12) to complete the law of planetary gear action.

Table 1: Planetary gear action law for automatic transmission.

HELD MEMBER	INPUT MEMBER	OUTPUT MEMBER	ROTATIONAL		
			SPEED	TORQUE	DIRECTION
Carrier	Sun	Ring	1	2	3
4	Ring	5	6	Increased	Same direction with input
7	8	9	Increase	Reduced	Same direction with input
(None)	Ring and Sun	Carrier	10	11	12

(10 marks)

- b) Gear ratio in planetary gear set is important to determine whether an output gear rotates faster or slower than input gear. For the case when the number of ring gear teeth is 56 and sun gear teeth is 24, and the planet carrier works as an input member while the ring gear become an output member;
 - i) Calculate the planetary gear ratio.

(10 marks)

- ii) Based on the above gear ratio, determine whether the output gear (output member) rotates faster or slower than the input gear (input member).

(2.5 marks)

- iii) Explain how it is happen (output gear faster or slower than input gear).

(2.5 marks)

- Q3** (a) Label the entire shift fork and rail arrangement for manual transmissions shown in Figure S3 (a).

(6 marks)

- (b) Explain what is means by an overdrive ratio.

(6 marks)

- (c) Calculate the gear ratio if the driven gear has 36 teeth and the driving gear has 12 teeth

(3 marks)

- (d) List four (4) possible causes for a manual transmission/ transaxle being difficult to shift

(10 marks)

- Q4** (a) What is the advantage of a constant velocity joint (CV-joint) over a universal joint.

(6 marks)

- (b) Name six (6) types of constant velocity (CV) joints

(12 marks)

- (c) Among the six (6) CV joints listed in Q4(b), describe which are most commonly used as an outboard joint and inboard joint

(7 marks)

- Q5**
- (a) Describe the function of Universal joint (U-joint) (4 marks)
 - (b) With simple sketches, illustrate and label the components for simple universal joint. (10 marks)
 - (c) Which series U-joint has the greatest torque capacity? and explain why? (5 marks)
 - (d) Explain why Cardan-type U-joint on a driveshaft must be within $\frac{1}{2}$ degree working angles. (6 marks)
- Q6**
- (a) Briefly explain the difference between **four-wheel drive (4WD)** and **all-wheel drive (AWD)** (6 marks)
 - (b) Traction is the maximum amount of force the tire can apply against the ground. Describe the factors that affect traction. (12 marks)
 - (c) Explain how transfer case works in part-time four-wheel drive vehicle system. (5 marks)

FINAL EXAMINATION

SEMESTER / SESSION : SEM I / 2010/2011
COURSE : POWERTRAIN & AXLES

PROGRAMME : 3 DDT
SUBJECT CODE : DDE 2043

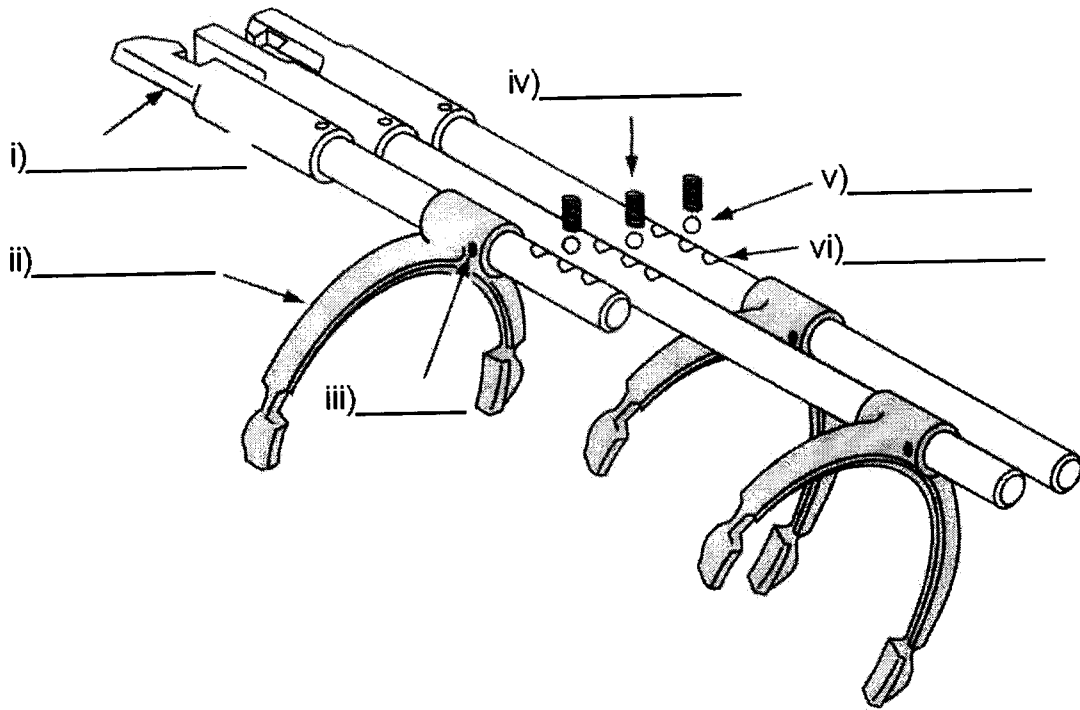

Figure Q3 (a)

- S1** (a) Nyatakan kenapa '*fleksibel*' disk pencekam berbeza daripada '*rigid* disk'.
(3 markah)
- (b) Jelaskan tiga fungsi utama '*master*' silinder di dalam sistem hidraulik pencekam.
(8 markah)
- (c) Terangkan kenapa '*dual mass flywheel*' lebih baik daripada '*single mass flywheel*'.
(6 markah)
- (d) Terangkan bagaimana untuk menentukan punca bunyi bagi; '*pilot bearing*, '*throwout bearing*' dan kurangnya pelinciran pada '*fork*' dan '*pivot*'.
(8 markah)
- S2** (a) Operasi asas bagi set di dalam transmisi automatik gear planetary boleh diwakili oleh hukum tindakan gear planetari. Hukum ini boleh dirumuskan di dalam jadual di bawah. Lengkapkan jadual di bawah (diwakili oleh nombor 1 hingga 12) untuk melengkapkan hukum tindakan gear planetary.

Jadual 1: Hukum tindakan gear planetari bagi transmisi automatik.

HELD MEMBER	INPUT MEMBER	OUTPUT MEMBER	ROTATIONAL		
			SPEED	TORQUE	DIRECTION
Carrier	Sun	Ring	1	2	3
4	Ring	5	6	Increased	Same direction with input
7	8	9	Increase	Reduced	Same direction with input
(None)	Ring and Sun	Carrier	10	11	12

(10 markah)

b) Nisbah gear di dalam set gear planetari sangat penting untuk menentukan samaada gear keluaran berputar lebih laju atau lebih perlahan daripada gear masukan. Bagi kes di mana gigi gear *ring* ialah 56 dan gigi gear *sun* ialah 24, dan '*planet carrier work's* sebagai satu kawan masukan sementara gear *ring* sebagai kawan keluaran;

i) Kirakan nisbah gear planetari.

(10 markah)

ii) Berdasarkan nisbah gear di atas, tentukan samaada gear keluaran (kawan keluaran) berputar lebih laju atau lebih perlahan daripada gear masukan (kawan masukan).

(2.5 markah)

iii) Jelaskan mengapa ini berlaku (gear keluaran laju atau lebih perlahan daripada gear masukan).

(2.5 markah)

S3 (a) Isikan keseluruhan '*shift fork*' dan '*rail arrangement*' bagi transmisi manual yang ditunjukkan di dalam Gambarajah S3 (a).

(6 markah)

(b) Terangkan apakah yang dimaksudkan dengan nisbah '*overdrive*'.

(6 markah)

(c) Kirakan nisbah gear jika gigi gear yang dipandu ialah 36 dan gigi gear yang memandu ialah 12.

(3 markah)

(d) Senaraikan empat (4) punca-punca kebarangkalian bagi transmisi manual sukar untuk penukaran.

(10 markah)

- S4** (a) Apakah kelebihan '*constant velocity joint (CV-joint)*' terhadap sambungan pelbagai guna. (6 markah)
- (b) Namakan **enam (6)** jenis '*constant velocity (CV) joints*'. (12 markah)
- (c) Antara **enam (6)** sambungan CV yang disenarikan dalam S4 (b), Terangkan jenis sambungan CV yang paling biasa digunakan pada '*outboard joint*' dan '*inboard joint*'. (7 markah)
- S5** (a) Terangkan fungsi '*Universal joint (U-joint)*'. (4 markah)
- (b) Dengan menggunakan lakaran, lukis dan labelkan komponen utama bagi '*simple universal joint*'. (10 markah)
- (c) Manakah siri sambungan-U (U-joint) yang memberikan nilai daya kilas yang terbesar? Dan Jelaskan kenapa? (5 markah)
- (d) Terangkan kenapa '*Cardan-type U-joint*' pada '*driveshaft*' mesti diantara $\frac{1}{2}$ darjah sudut kerja. (6 markah)

- S6**
- (a) Terangkan perbezaan diantara '*four-wheel drive (4WD)*' dan '*all-wheel drive (AWD)*'
(6 markah)
- (b) Daya penarik adalah daya yang maksima yang boleh dikenakan oleh tayar terhadap permukaan jalan. Terangkan factor-faktor yang boleh menyebabkan daya penarik.
(12 markah)
- (c) Terangkan bagaimana kotak pemindah berfungsi pada sistem pacuan empat roda separuh masa.
(5 markah)

PEPERIKSAAN AKHIR

SEMESTER / SESSION : SEM I / 2010/2011
BIDANG : POWERTRAIN & AXLES

PROGRAM : 3 DDT
KOD SUBJEK : DDE 2043

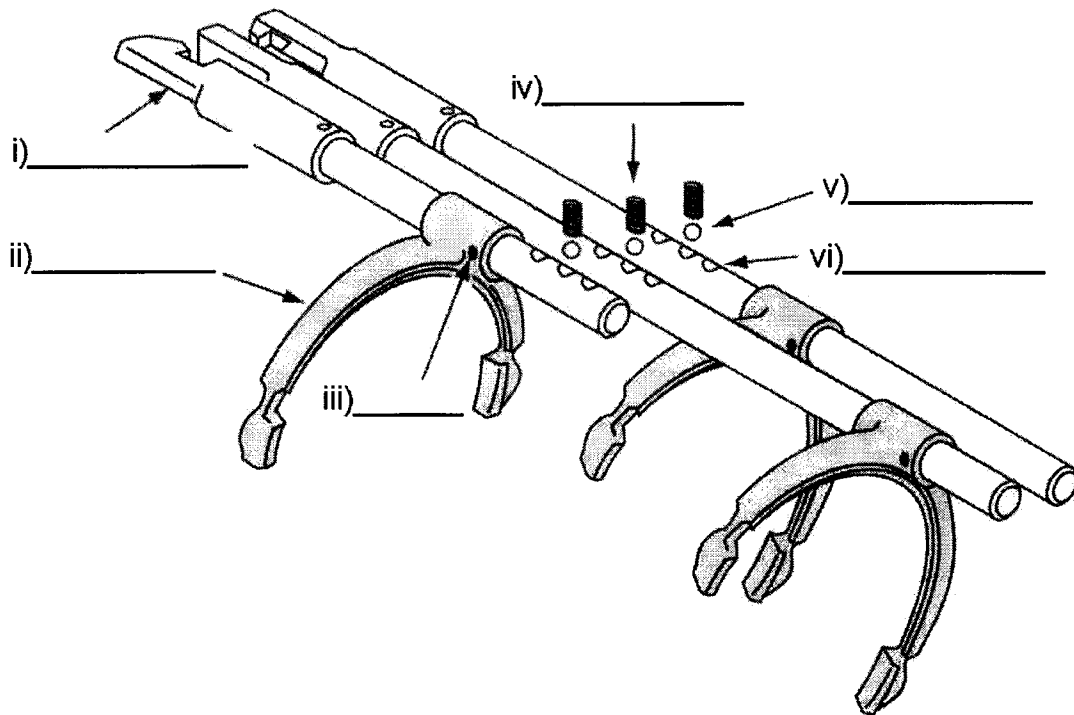

Gambarajah S3 (a)