



UTHM
Universiti Tun Hussein Onn Malaysia

UNIVERSITI TUN HUSSEIN ONN MALAYSIA

**FINAL EXAMINATION
SEMESTER II
SESSION 2017/2018**

COURSE NAME : INDUSTRIAL POWER SYSTEMS
COURSE CODE : BEF 44903
PROGRAMME : BACHELOR OF ELECTRICAL
ENGINEERING WITH HONOURS
EXAMINATION DATE : JUNE / JULY 2018
DURATION : 3 HOURS
INSTRUCTION : ANSWER ALL QUESTIONS

TERBUKA

THIS QUESTION PAPER CONSISTS OF NINE (9) PAGES

- Q1** (a) A distribution transformer is to be installed at the basement area of a factory. Recommend proper type of the distribution transformer that will be suitable for this installation by discussing **three (3)** main technical aspects. (3 marks)
- (b) **Table Q1(b)** depicts the load utilisation in a manufacturing factory. Demand estimation has to be made for these loads based on proper utilisation factor (k_u) and diversity factor (k_s). Three (3) levels of diversity factor needs to be assumed: distribution box (DB), plant distribution box (PDB) and main general distribution board (MGDB) before connecting to the distribution transformer.
- (i) Prepare the electrical block diagram for the installation by showing the utilisation of k_u and k_s . (5 marks)
- (ii) Analyse the estimated demand at each PDB. (5 marks)
- (iii) Decide the total estimated demand that is to be reached at the distribution transformer. (2 marks)
- (c) The installed distribution transformer as mentioned in **Q1(b)** is rated at 500 kVA 11 kV/ 400 V and operating at 50 Hz. 3-core copper, XLPE power cables are laid from the distribution transformer to the MGDB. The cables are laid 120 cm underground in horizontal formation with 60 cm spacing to each other. The number of cables in a group is 2 Nos. The ground ambient temperature is 40° C and the thermal resistivity of soil is 150 °C cm/Watt.
- (i) If the fault clearing time of the network is 8 cycles with the short circuit capacity (kVA_{SC}) of 200 times the loading, select the initial size of the cable based on the short circuit current withstand capacity criteria. (4 marks)
- (ii) Analyse the cable size as identified in **Q1(c)(i)** by considering the continuous current carrying capacity criteria. (6 marks)
- Q2** (a) Summarise typical consequences when having improper battery sizing. (3 marks)
- (b) A 5 MVA, 11 kV/ 415 V, Y-connected step-down transformer has been installed to serve an industrial plant as depicted in **Figure Q2(b)**. The resistance (R_{pu}) and the reactance (X_{pu}) for the transformer is given as 0.5% and 7.5%, respectively. The power system is operating at 50 Hz.

TERBUKA

- (i) Classify the total resistance (R_{tot}) and inductance (L_{tot}) values to be observed in the single phase equivalent circuit for harmonic study purpose as depicted in **Figure Q2(b)(i)**.
(5 marks)
- (ii) Investigate the parallel resonant frequency when the installed power factor correction is rated at 400 kVAr and 650 kVAr based on the result obtained in **Q2(b)(i)**.
(6 marks)
- (iii) Recommend the appropriate tune filter type as a harmonic treatment based on the results obtained in **Q2(b)(ii)** and its correct placement in the single-phase equivalent circuit.
(2 marks)
- (c) Typically during motor starting, there is high induced current that builds-up in the rotor which results excessive current peak that could jeopardise the winding and insulation in the motor itself. Thus, a proper starting method is normally used on the industrial scale motor in order to reduce this problem.
- (i) Construct the typical star-delta motor starting circuit.
(4 marks)
- (ii) Analyse the circuit mentioned in **Q2(c)(i)**, in terms of the principles used when starting the motor, the resultant currents and torques.
(5 marks)
- Q3** (a) Summarise **two (2)** non-technical benefits gained by industry that having proper load monitoring system in place.
(2 marks)
- (b) A small scale industrial plant is designed to having load shedding scheme activated when its lines are overloaded based on the parameters as shown in **Table Q3(b)**. The plant corresponded main power distribution circuit is shown in **Figure Q3(b)**.
- (i) Plot a graph that outlining the cycle response by 'Relay 81' in **Figure Q3(b)** to activate load shedding procedure using the frequency monitoring scheme method.
(5 marks)
- (ii) Investigate the relative overload (ΔP) to be shed in kW based on the frequency tolerance set by the plant.
(7 marks)

TERBUKA

- (c) Typically, the load shedding scheme in industry can be managed either via the conventional Programmable Logic Controller (PLC) based or the new-tech Intelligent Load Shedding (ILS) method.
- (i) Analyse the ILS in terms of the working concept, necessity and response parameters.
(7 marks)
- (ii) Construct the recommended operation logic flow chart of expert system considerations for the load shedding procedure.
(4 marks)
- Q4** (a) List **two (2)** important protective devices that can be used to isolate the faulty section in an industrial power system.
(2 marks)
- (b) Obtain the symmetrical components for the set of unbalanced currents $I_a = 10\angle 20^\circ$, $I_b = 45\angle -45^\circ$, $I_c = 8\angle 100^\circ$.
(5 marks)
- (c) A 35 MVA 15.6 kV industrial synchronous generator has a sub-transient reactance of 0.20 per unit. The negative-sequence and zero-sequence reactances are 0.40 and 0.10 per unit, respectively. The neutral of the generator is solidly grounded. Analyse the sub-transient current in the generator and the line-to-line voltages for the sub-transient conditions when a single line-to-ground fault occurs at the generator terminals with the generator operating unloaded at rated voltage. The resistance is negligible.
(18 marks)

– END OF QUESTIONS –

TERBUKA

FINAL EXAMINATION

SEMESTER/SESSION : II/ 2017/ 2018

PROGRAMME : BEV

COURSE NAME : INDUSTRIAL POWER SYSTEMS

COURSE CODE : BEF 44903

Table Q1(b)

Load Utilisation	Apparent Power (kVA)
Plant A	
Lathe No. 1 (DB – PDB – MGDB)	8
Lathe No. 2 (DB – PDB – MGDB)	10
Lathe No. 3 (DB – PDB – MGDB)	15
10 Socket Outlets, 16/ 20A (PDB – MGDB)	43
40 Fluorescent Lamps (PDB – MGDB)	2
Plant B	
Compressor (DB – PDB – MGDB)	25
Heater (DB – PDB – MGDB)	15
5 Socket Outlets, 16/ 20A (PDB – MGDB)	20
15 Fluorescent Lamps (PDB – MGDB)	1
10 Motors, each rating at 10 kW (PDB – MGDB)	120
Plant C	
Ventilation (DB – PDB – MGDB)	4.5
Oven (DB – PDB – MGDB)	20
40 Socket Outlets, 16/ 20A (PDB – MGDB)	170
25 Fluorescent Lamps (PDB – MGDB)	1.5

TERBUKA

FINAL EXAMINATION

SEMESTER/SESSION : II/ 2017/ 2018
 COURSE NAME : INDUSTRIAL POWER SYSTEMS

PROGRAMME : BEV
 COURSE CODE : BEF 44903

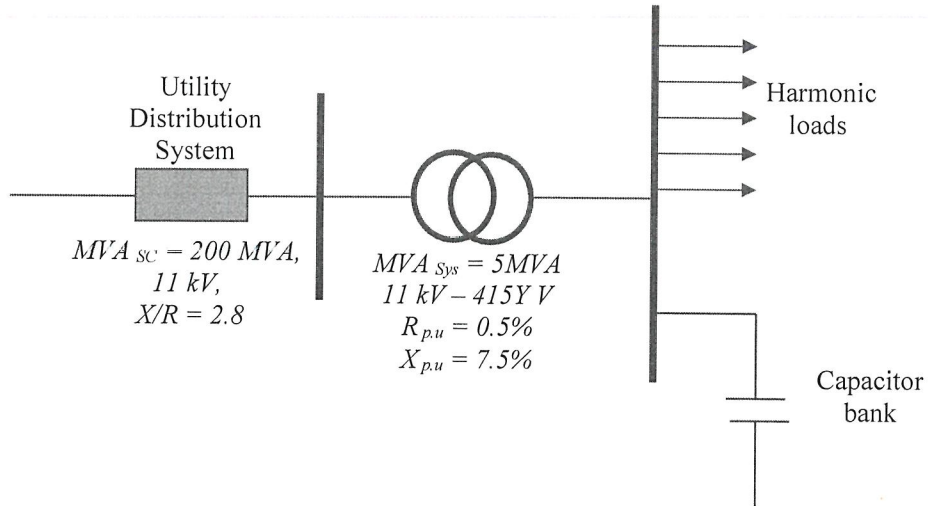

Figure Q2(b)

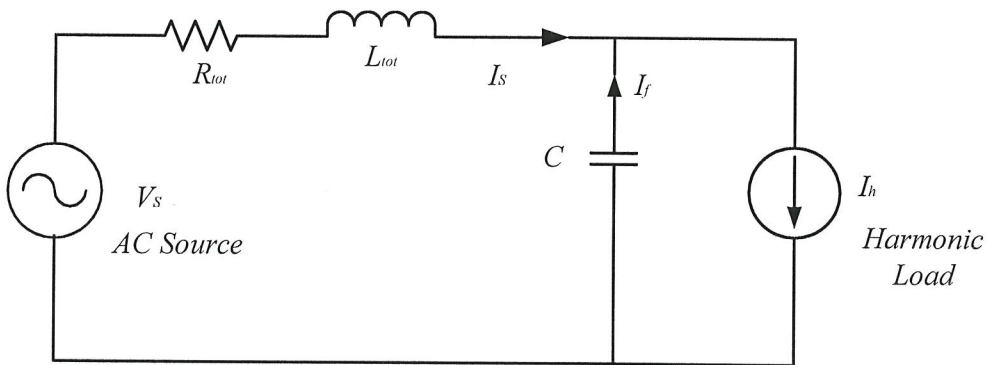

Figure Q2 (b)(i)

TERBUKA

FINAL EXAMINATION

SEMESTER/SESSION : II/ 2017/ 2018
 COURSE NAME : INDUSTRIAL POWER SYSTEMS

PROGRAMME : BEV
 COURSE CODE : BEF 44903

Table Q3(b)

Plant Parameter	Value
Load reduction factor	1.5
Fundamental frequency	60 Hz
Frequency tolerance	$\pm 1.5\%$
Base apparent power	1.5 MVA
Overall p.f	0.85

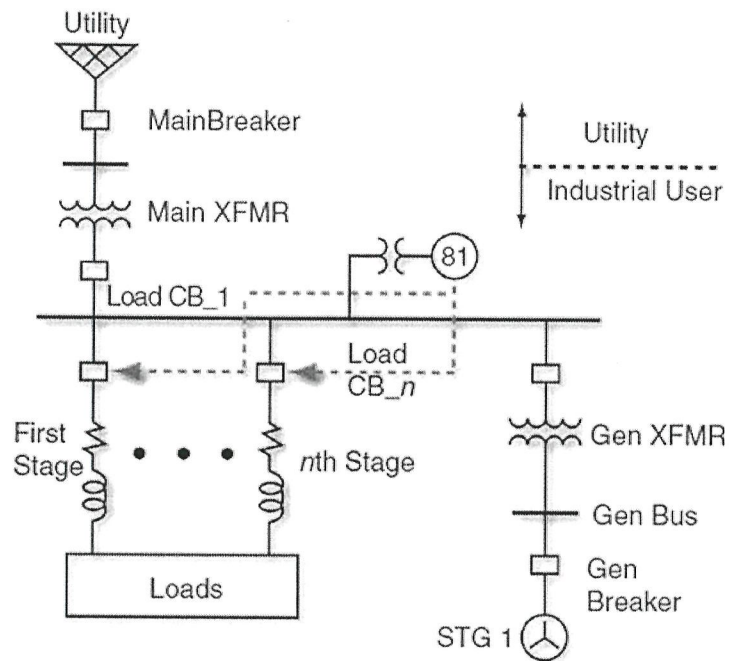

Figure Q3(b)

TERBUKA

FINAL EXAMINATION

SEMESTER/SESSION : II/ 2017/ 2018
 COURSE NAME : INDUSTRIAL POWER SYSTEMS

PROGRAMME : BEV
 COURSE CODE : BEF 44903

Appendix A

$$K = 226 \sqrt{\ln \left(1 + \frac{T_2 - T_1}{234.5 + T_1} \right)}, \quad A = \frac{\sqrt{I_{SC}^2 t}}{K}$$

Insulation material	Final temperature, T ₂ (°C)	Initial temperature, T ₁ (°C)
PVC	160	70
Butyl Rubber	220	85
XLPE/ EPR	250	90

TABLE 4E4A – Multicore 90 °C armoured thermosetting insulated cables (COPPER CONDUCTORS)

Air ambient temperature: 30 °C
 Ground ambient temperature: 20 °C
 Conductor operating temperature: 90 °C

CURRENT-CARRYING CAPACITY (amperes):

Conductor cross-sectional area	Reference Method C (clipped direct)		Reference Method E (in free air or on a perforated cable tray etc, horizontal or vertical)		Reference Method D (direct in ground or in ducting in ground, in or around buildings)	
	1 two-core cable, single-phase a.c. or d.c.	1 three- or 1 four-core cable, three-phase a.c.	1 two-core cable, single-phase a.c. or d.c.	1 three- or 1 four-core cable, three-phase a.c.	1 two-core cable, single-phase a.c. or d.c.	1 three- or 1 four-core cable, three-phase a.c.
	2	3	4	5	6	7
l (mm ²)	(A)	(A)	(A)	(A)	(A)	(A)
1.5	27	23	29	25	25	21
2.5	36	31	39	33	33	28
4	49	42	52	44	43	36
6	62	53	66	56	53	44
10	85	73	90	78	71	58
16	110	94	115	99	91	75
25	146	124	152	131	116	96
35	180	154	188	162	139	115
50	219	187	228	197	164	135
70	279	238	291	251	203	167
95	338	289	354	304	239	197
120	392	335	410	353	271	223
150	451	386	472	406	306	251
185	515	441	539	463	343	281
240	607	520	636	546	395	324
300	698	599	732	628	446	365
400	787	673	847	728	-	-

TERBUKA

FINAL EXAMINATION

SEMESTER/SESSION : II/ 2017/ 2018
 COURSE NAME : INDUSTRIAL POWER SYSTEMS

PROGRAMME : BEV
 COURSE CODE : BEF 44903

Appendix B

Ground Temp. (°C)	20	25	30	35	40	45	50
Rating Factor	1.12	1.08	1.04	0.96	0.91	0.87	0.82

Spacing	No. of cables in group				
	2	3	4	6	8
Touching	0.79	0.69	0.62	0.54	0.50
15 cm	0.82	0.75	0.69	0.61	0.57
30 cm	0.87	0.79	0.74	0.69	0.66
45 cm	0.90	0.83	0.79	0.75	0.72
60 cm	0.91	0.86	0.82	0.78	0.76

Cable size	Depth of laying (cm)					
	75	90	105	120	150	180 ≥
up to 25 sq. mm.	1.00	0.99	0.98	0.97	0.96	0.95
25 to 300 sq. mm	1.00	0.98	0.97	0.96	0.94	0.93
above 300 sq. mm.	1.00	0.97	0.96	0.95	0.92	0.91

Nominal area of conductor in sq. mm	Rating factors for value of Thermal Resistivity of Soil in °C cm / Watt					
	100	120	150	200	250	300
25	1.24	1.08	1.00	0.91	0.84	0.78
35	1.15	1.08	1.00	0.91	0.84	0.77
50	1.15	1.08	1.00	0.91	0.84	0.77
70	1.15	1.08	1.00	0.90	0.83	0.76

TERBUKA