



UTHM

Universiti Tun Hussein Onn Malaysia

UNIVERSITI TUN HUSSEIN ONN MALAYSIA

**FINAL EXAMINATION
SEMESTER II
SESSION 2015/2016**

COURSE NAME : MEDICAL MEASUREMENT SYSTEM

COURSE CODE : BEU41003

PROGRAMME : BEJ

EXAMINATION DATE : JUNE 2016 / JULY 2016

DURATION : 3 HOURS

INSTRUCTION : 1. **WRITE ALL THE ANSWERS IN THIS QUESTIONS BOOKLET**
2. **ANSWER ALL QUESTIONS**

THIS QUESTION PAPER CONSISTS OF **THIRTEEN (13)** PAGES

Q1 (a) The instrumentation amplifier is a key design component to almost all biopotential measurement.

(i) Discuss the reasonable usage of the amplifier in almost all medical measurement system.

(4 marks)

(ii) Derive the equations for the gain of Op-amp A_3 instrumentation amplifier in **Figure Q1(a)(ii)** and calculate the overall circuit gain. Given that:

$$R_2 = 50\text{k}\Omega, R_1 = 0.5\text{k}\Omega \text{ and } R_3 = R_4 = 50\text{k}\Omega.$$

The output voltage from Op-amp A_1 is V_3 and the output voltage from Op-amp A_2 is V_4 .

(10 marks)

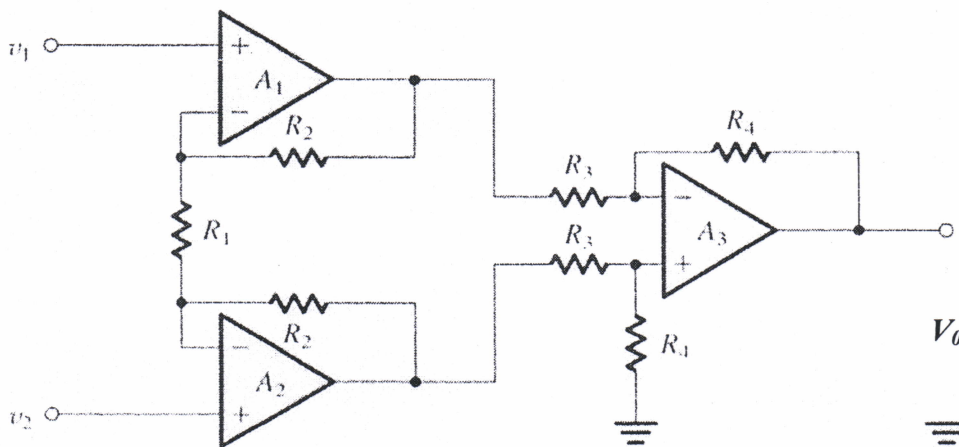

Figure Q1(a)(ii)

(b) (i) Explain the usage of isolation amplifiers in medical measurement system.

(3 marks)

(ii) Draw the block diagram of the basic design of an isolation amplifier and explain the function of each block.

(8 marks)

CONFIDENTIAL

Q2 (a) Explain the principle of photoplethysmogram (PPG) and illustrate the PPG signal.

(5 marks)

(b) Draw and explain the **TWO (2)** modes of photoplethysmogram (PPG).

(8 marks)

MUHAMMAD KAZIB BIN ALI
Kampus
Jabatan Kejuruteraan Elektrik dan Elektronik
*Kuliah Kejuruteraan Elektrik dan Elektronik
*Jabatan Kejuruteraan Elektrik dan Elektronik

(c) Design the block diagram of photoplethysmogram (PPG).

(7 marks)

(d) Explain briefly Pulse Transit Time (PTT).

(5 marks)

UNIVERSITY OF BRISTOL
SCHOOL OF ENGINEERING
INSTITUTION OF MECHANICAL ENGINEERS
INSTITUTION OF ELECTRICAL ENGINEERS
INSTITUTION OF CIVIL ENGINEERS
INSTITUTION OF CHEMICAL ENGINEERS

Q3 (a) **Figure Q3(a)** shows the oscilloscope display of the blood pressure measurement using oscillometric sensor. From the result shown, calculate the diastolic pressure (mmHg) and systolic pressure (mmHg). Given that the VOLT/DIV for both channels (CH1 and CH2) are set at 2 V/div while the TIME/DIV are set at 5 Sec/DIV.

(6 marks)

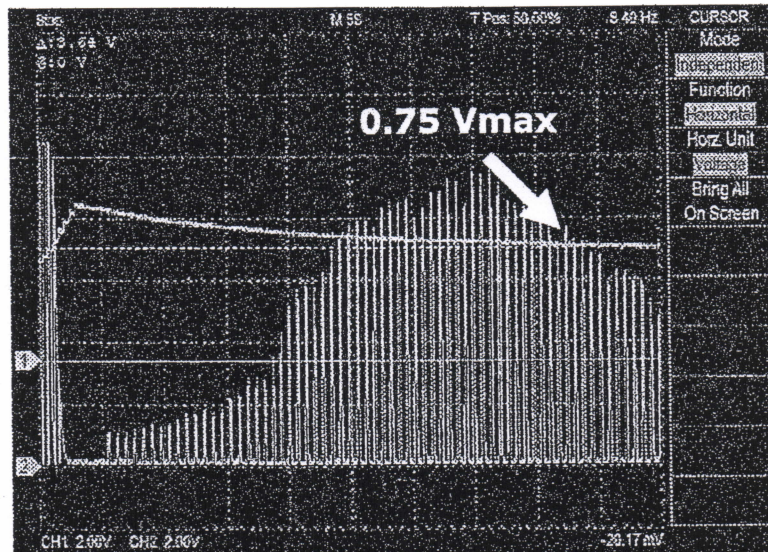
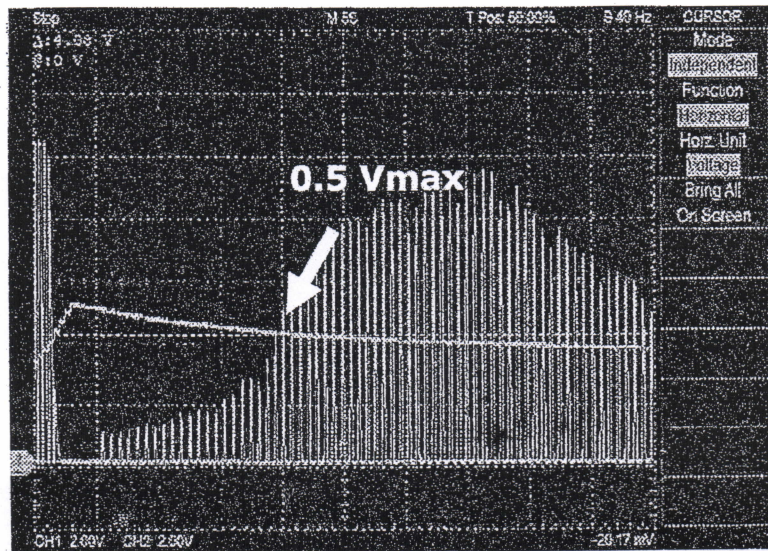

Figure Q3(a)

MOHAMED HANAN DAJAHOM
* * * * *
* * * * *
* * * * *
* * * * *

ИСТОРИЧЕСКАЯ ПАМЯТЬ
РОССИИ
Исторический музей
ул. Ильинская, 10/12, Москва
Тел. (495) 225-1111

- (b) Using the diastolic and systolic pressure measured in **Figure Q3(a)**, calculate the mean arterial pressure.

(2 marks)

- (c) A physiotherapist would like to monitor the heart rate of a subject using an electrocardiogram (ECG) while exercising. Exercise causes three main difficulties for measurement of the Electrocardiogram (ECG):

- The movement of artifacts.
- Sweat on the electrodes.
- Artifacts from the Electromyogram (EMG).

- (i) Explain the definition of artifacts.

(2 marks)

CONFIDENTIAL

- (ii) Determine the type of artifact that affect the ECG waveform in **Figure Q3(c)(ii)** and describe the possible causes. Explain if a filter can be used to rectify the signal.

(3 marks)

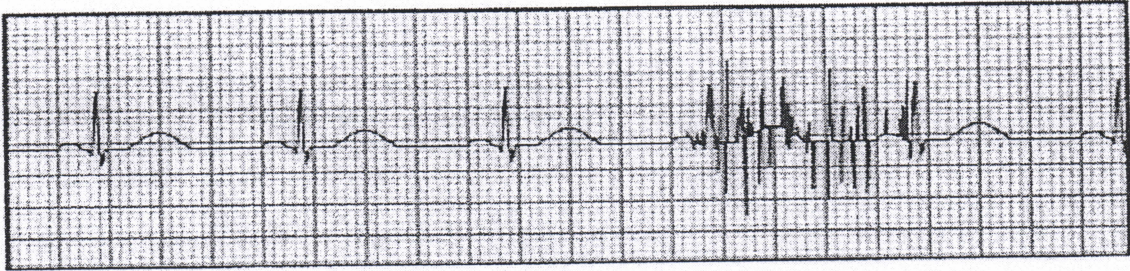

Figure Q3(c)(ii)

- (iii) Setup the connection of LEAD I, LEAD II and LEAD III for the ECG measurement in **Figure Q3(c)(iii)**.

(6 marks)

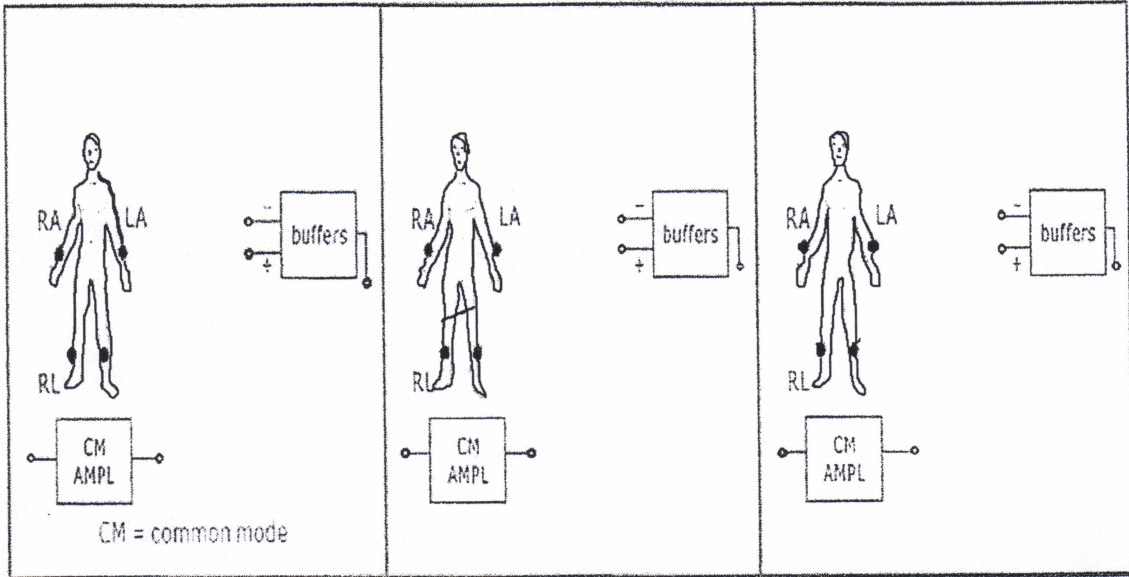

Figure Q3(c)(iii)

- (iv) Label the P, Q, R, S, T events in **Figure Q3(c)(iv)**. Estimate the heart rate (beats/min) based on the corresponding diagram.

(6 marks)



Figure Q3(c)(iv)

Q4 (a) (i) Explain the principles of respiratory ventilation detection. Use diagram if necessary.

(5 marks)

- (ii) Illustrate and compare the difference between measured waveforms of respiratory while relax with the respiratory while exercise.

(7 marks)

- (b) (i) In the process of your heart pumps blood through your body, you can feel a pulsing in some of the blood vessels close to the skin's surface, such as in your wrist, neck, or upper arm. Demonstrate the counting of your pulse rate when your heart is beating.

(5 marks)

- (ii) Propose a complete method for transferring circuit principles of pulse rate measurement for heart rate analysis and measurement purposes.

(8 marks)

- **END OF QUESTION -**