

CONFIDENTIAL



UNIVERSITI TUN HUSSEIN ONN MALAYSIA

**FINAL EXAMINATION
SEMESTER I
SESSION 2015/2016**

COURSE NAME : MECHATRONICS MECHANISM
COURSE CODE : BEH41103
PROGRAMME : BACHELOR OF ELECTRONIC
ENGINEERING WITH HONOURS
EXAMINATION DATE : DECEMBER 2015/ JANUARY 2016
DURATION : 3 HOURS
INSTRUCTION : ANSWER ALL QUESTIONS

THIS QUESTION PAPER CONSISTS OF **EIGHT (8)** PAGES

CONFIDENTIAL

- Q1 (a)** **Figure Q1(a)** shows an epicyclic gear box that has a fixed outer gear C and 75% efficiency. The input is the gear D that rotates at 200 rev/min clockwise viewed from the left with a torque of 40 Nm. Gear B and gear D has 140 teeth and 20 teeth respectively. Evaluate the output speed and direction of the epicyclic gear box. (5 marks)

- (b) An 11.5 cm wide and 1.2 cm thick belt transmits 11 kW between two parallel shafts. **Figure Q1(b)** shows two types of connection between the belt and the shafts. The distance between the shafts is 250 cm and the diameter of the smaller pulley is 60 cm. The driving and the driven shaft rotate at 100 rpm and 240 rpm respectively. The coefficient of friction between the belt and the pulley is 0.25. Analyse the stress in the belt if the two pulleys are connected by open belt and cross belt. (15 marks)

- Q2 (a)** A rotating shaft carries four masses A, B, C and D which are radially attached to it. The mass centres are 30 mm, 38 mm, 40 mm and 35 mm respectively from the axis of rotation. The masses A, C and D are 7.5 kg, 5 kg and 4 kg respectively. The axial distances between the planes of rotation of A and B is 400 mm and between B and C is 500 mm. The masses A and C are at right angles to each other. For a complete balance, calculate:
- (i) The angles between the masses B and D from mass A. (6 marks)
 - (ii) The axial distance between the planes of rotation of C and D. (2 marks)
 - (iii) The magnitude of mass B. (2 marks)

- (b) The displacement of a body performing simple harmonic motion is described by the following equation

$$x = A \sin(\omega t + \phi)$$

where A is the amplitude, ω is the natural frequency and ϕ is the phase angle. Given $A = 20$ mm, $\omega = 50$ rad/s and $\phi = \pi/8$ radian.

- (i) Analyse the frequency and the period time. (5 marks)
- (ii) Evaluate the displacement, velocity and acceleration when $t = T/4$. (5 marks)

- Q3** (a) Discuss briefly the various types of friction experienced by a body. (4 marks)
- (b) In a screw jack, the helix angle of thread is α and the angle of friction is ϕ . Prove that its efficiency is maximum, when $2\alpha = (90^\circ - \phi)$. (5 marks)
- (c) A load of 25 kN is raised by means of a screw jack, having a mean diameter threaded screw of 12.5 mm and pitch of 50 mm. The coefficient of friction between the screw and the nut is 0.13. Determine:
- (i) The force required on the screw to raise the load. (2 marks)
- (ii) The torque required on the screw to raise the load. (2 marks)
- (iii) The torque required to lower the load. (4 marks)
- (iv) The ratio of the torque required to raise the load to the torque required to lower the load. (1 mark)
- (v) The efficiency of the machine. (2 marks)

- Q4** **Figure Q4** shows a toggle mechanism. The slider D is constrained to move on a horizontal path. The crank OA is rotating in the counter-clockwise direction at a speed of 180 r.p.m. The dimensions of various links are as follows :

$$OA = 180 \text{ mm} ; CB = 240 \text{ mm} ; AB = 360 \text{ mm} ; \text{ and } BD = 540 \text{ mm}$$

For the given configuration, deduce:

- (a) Velocity of slider D. (4 marks)
- (b) Angular velocity of links AB, CB and BD. (6 marks)
- (c) Velocities of rubbing on the pins of diameter 30 mm at A and D. (6 marks)
- (d) Torque applied to the crank OA, for a force of 2 kN at D. (4 marks)

- Q5** (a) **Figure Q5(a)** shows a fork lift truck. It is used to lift pallets, complete with their heavy loads. The forks on the front of the truck move up and down the vertical track.
- (i) Propose the missing mechanism that allows the up/down motion of the forks.
(Please draw your proposed mechanism in the magnified area) (4 marks)
- (ii) Explain how the mechanism works. (4 marks)
- (b) Compare the applications, advantages and disadvantages of:
- (i) Belt drive (6 marks)
- (ii) Gear drive (6 marks)

- END OF QUESTION -

FINAL EXAMINATION

SEMESTER/SESSION : SEM I/20152016

PROGRAMME : BEJ

COURSE : MECHATRONICS MECHANISM

COURSE CODE : BEH41103

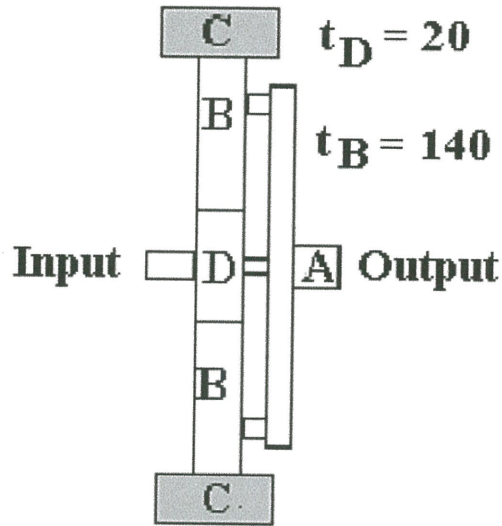

FIGURE Q1(a)

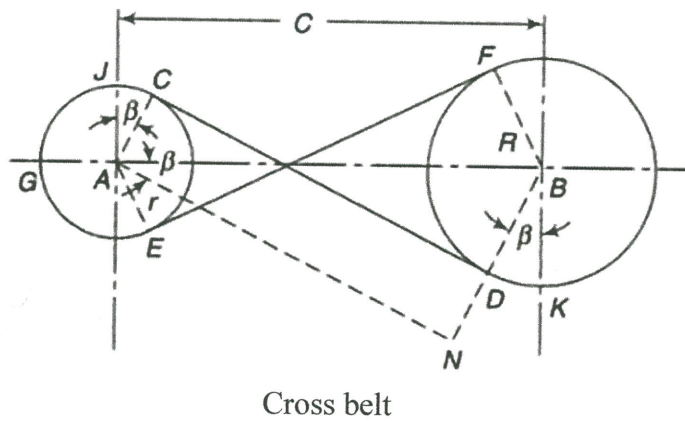
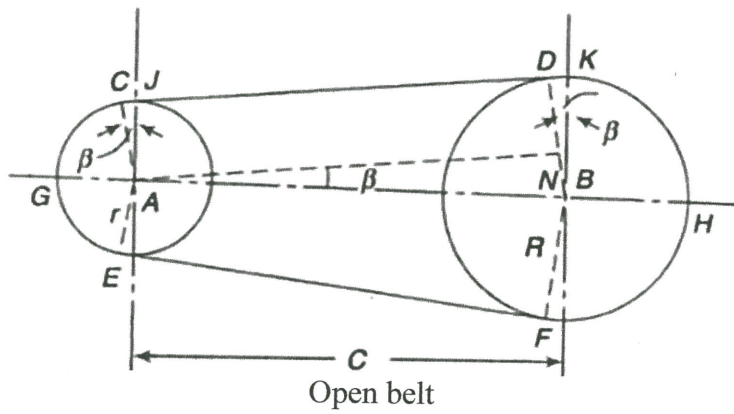

FIGURE Q1(b)

FINAL EXAMINATION

SEMESTER/SESSION : SEM I/20152016
COURSE : MECHATRONICS MECHANISM

PROGRAMME : BEJ
COURSE CODE : BEH41103

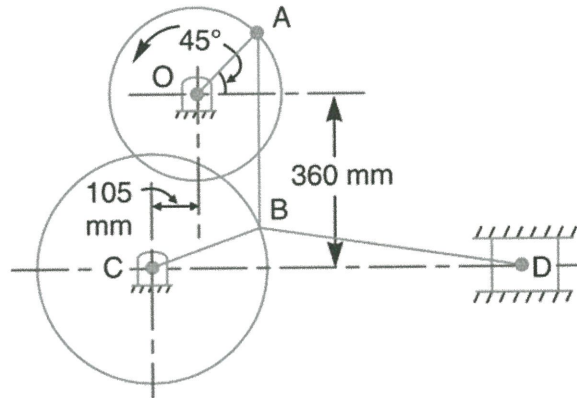

FIGURE Q4

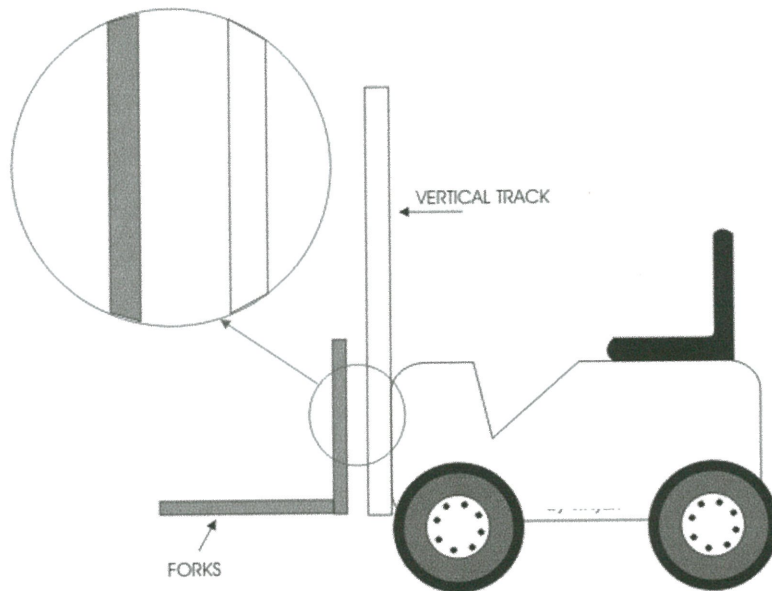

FIGURE Q5(a)

FINAL EXAMINATION

SEMESTER/SESSION : SEM I/20152016
 COURSE : MECHATRONICS MECHANISM

PROGRAMME : BEJ
 COURSE CODE : BEH41103

FORMULA

1. Gear ratio, $GR = \frac{N_A}{N_B} = \frac{t_B}{t_A}$

where N_A is the input speed, N_B is the output speed, t_A is the number of teeth on gear A and t_B is the number of teeth on gear B.

2. The effect of slip on the velocity ratio

$$VR = \frac{N_B}{N_A} = \left(\frac{D_A}{D_B} \right) \left(\frac{100 - S}{100} \right)$$

where N_A is rotational speed of motor shaft, N_B is rotational speed of the main shaft, D_A is the diameter of motor pulley (driver), D_B is the diameter of 1st pulley on the main shaft (driven) and S is the percentage slip.

3. Efficiency, $\eta = \frac{\text{Power out}}{\text{Power in}} \times 100\%$

4. Shaft power, $P = \frac{2\pi NT}{60}$

where N is the speed and T is the torque

5. linear velocity on a circle $v = \omega D / 2$

where ω is the angular velocity and D is the diameter of a circle.

6. Power transmission of belt drives, $P = (T_1 - T_2)v$

where T_1 is the tension on the tight side, T_2 is the tension on the slack side and v is the linear velocity of the belt.

7. Maximum power transmission, $P = T_1 k v$

$$k = 1 - \frac{1}{e^{\mu\theta}}$$

where T_1 is the tension on tight side, v is the linear velocity of the belt, k is the constant, μ is the coefficient of friction between belt and pulley and θ is the angle of lap of the belt over pulley.

8. Friction tensions ratio for flat belt, $\frac{T_1}{T_2} = e^{\mu\theta}$

Friction tension ration for v-belt and rope, $\frac{T_1}{T_2} = \frac{e^{\mu\theta}}{\sin \alpha}$

where T_1 is the tension on tight side, T_2 is the tension on the slack side, θ is the angle of lap of the belt over pulley, μ is the coefficient of friction between belt and α is the angle of the groove.

9. Tension, $T = b \times t \times f$

where b is the width of the belt, t is the thickness of belt and f is the stress.

10. Centrifugal force, $F_{c1} = m_1 \omega^2 r_1 \text{N}$

where m_1 is the mass attached to the shaft in kg, r_1 is the distance of centre of gravity of the revolving mass m_1 from the axis rotation and ω is the angular velocity of the shaft in rad/s.

11. Effort for upward motion

$$P_0 = mg \tan \alpha \text{ without friction } (\phi=0)$$

$$P = mg \tan(\alpha + \phi) \text{ with friction}$$

$$= \frac{mg(\tan \alpha + \tan \phi)}{1 - \tan \alpha \tan \phi}$$

Where mg is the weight of the body, ϕ is the angle of friction and α is the angle of inclination of the plane to the horizontal.

$$\text{But } \tan \alpha = \frac{p}{\pi d_m} \text{ and } \tan \phi = \mu$$

Where p is the pitch, d_m is the mean diameter of the screw and μ is the coefficient of friction

12. Effort for downward motion

$$P = mg \tan(\phi - \alpha)$$

$$= \frac{mg(\tan \alpha - \tan \phi)}{1 - \tan \alpha \tan \phi}$$

Where mg is the weight of the body, ϕ is the angle of friction and α is the angle of inclination of the plane to the horizontal.

13. Horizontal force applied tangentially at the end of a tommy bar in a horizontal plane,

$$P_e = \frac{P \times r}{L}$$

where P_e is the force applied by the tommy bar, P is the force applied at screw tangentially in a horizontal plane, r is the radius of the screw and L is the horizontal distance between central axis of the screw and the end of the tommy bar.