

**CONFIDENTIAL**



**UNIVERSITI TUN HUSSEIN ONN MALAYSIA**

**FINAL EXAMINATION  
SEMESTER II  
SESSION 2012/2013**

**COURSE NAME : INDUSTRIAL POWER SYSTEMS**  
**COURSE CODE : BEF 44903**  
**PROGRAMME : BEF**  
**EXAMINATION DATE : JUNE 2013**  
**DURATION : 3 HOURS**  
**INSTRUCTION : ANSWER ALL QUESTIONS**

**THIS QUESTION PAPER CONSISTS OF TEN (10) PAGES**

**CONFIDENTIAL**

- Q1** (a) Explain two (2) advantages of installing Delta-Grounded Star configuration of distribution transformer in industrial power system.

(4 marks)

- (b) State three (3) different types of dry distribution transformer for industry use.

(3 marks)

- (c) Table Q1(c) depicts the loading of Motor Control Centre (MCC) in an electronic based factory. Prepare a proper table to calculate the total loading of the MCC by indicating the three-phase and single-phase loads.

(5 marks)

- (d) The MCC in Q1(c) is served by a three-phase cable installed from the 415 V main switchgear feeder. The insulation type and the conductor type of the cable are PVC and copper, respectively. The short circuit current capacity is to be assumed as 100 times of the MCC load current and the fault clearing time is taken as 0.5 second.

- (i) Analyse the minimum size of the cable required based on the short circuit withstand capacity criteria (Refer to Appendix A)
- (ii) Evaluate again the cable size obtained in Q1(d)(i) for continuous current carrying capacity criteria based on Table Q1(d)(1) to Table Q1(d)(3). The cable is directly clipped on the wall (Reference Method C) with the ambient temperature of 45°C. The cable is laid on 3 Nos. of cable rack with number of cables/ rack to be 3. Recommend the new cable size if necessary

(13 marks)

- Q2** (a) Give three (3) possible root causes of fault to be happened in industrial power system.

(3 marks)

- (b) Figure Q2(b) shows a partial industrial installation with two incoming sources and its appropriate protective devices (PD). Choose proper type of protective device for PD 1 to PD 4 in order to minimise the tripping area with the occurrence of Fault A as shown in the figure. Sketch and explain the circulation of short circuit current and the operation of the protective devices.

(7 marks)

- (c) Figure Q2(c) illustrates a differential protection scheme for a food processing factory. The 1 MVA step-down transformer is connected in Delta-Grounded Star configuration with voltage level of 11 kV – 415 V. A percentage differential relay with 15% slope setting is utilised for this overcurrent protection scheme. The primary side current transformer ratio is given as 10 : 1.

- (i) Propose a proper value for the secondary current transformer ratio
- (ii) Analyse the differential percentage between the incoming current and the outgoing current with the proposed current transformer ratio as given in Q2(c)(i)
- (iii) Evaluate the minimum secondary current to activate the percentage differential relay if the primary current is assumed to be constant

(15 marks)

- Q3** (a) Explain two (2) benefits of load shedding scheme to industrial consumers.

(4 marks)

- (b) A factory having a load shedding scheme with the load reduction factor ( $d$ ) of 2. The MVA base for the load shedding calculation is 10 MVA and the standard frequency variation ( $f$ ) is 1%. The factory is fed with 50 Hz ( $f_0$ ) supply and the overall power factor is to be assumed as 0.85. The frequency variation during the load shedding is given as:

$$f = \frac{1 + \frac{d-1}{d} \Delta P}{1 + \Delta P} f_0$$

Determine the relative overload ( $\Delta P$ ) to be shed in kW.

(5 marks)

- (c) A large industrial plant receives 3-phase electric power from the local utility. The following loads are being fed in the plant at 11.0 kV:
- 1.2 + j 1.2 MVA
  - 2.0 MW at 0.8 (lag) power factor
  - 800 kW of pure heating and lighting (negligible reactive power) load
  - A number of induction motors: total power output of 3,000 HP, with a composite efficiency of 0.85 and power factor of 0.88 (lag)
- (i) Analyse the total active power, reactive power and apparent power
  - (ii) Compute the overall (composite) load power factor and the full load current

- (iii) Plan the capacitive VAR requirements for the capacitor bank if the overall plant power factor is to be improved to 0.95 lag
- (iv) Draw the simplified one-line diagram and the phasor diagram (power triangle)

(16 marks)

- Q4** (a) Propose three (3) ideas to enhance energy efficiency in industrial power system.

(6 marks)

- (b) An inverter based UPS is installed in a factory to run 10 Nos of 250 W luminaires for at least 5 hours during the blackout period. The battery bank output voltage is 48 V and the inverter efficiency is assumed as 85%. Decide a proper battery size (in AH) if the high discharge rates is to be considered during the operation.

(5 marks)

- (c) An industrial power system having three outgoing feeders that taps from the main utility supply and UPS system as depicted in Figure Q4(c). Assume all the loads are operating at 415 V. The UPS is designed to power up the critical loads during power outage for at least 3 hours as follows:

- 30% of feeder 1
- 10% of feeder 2
- 15% of feeder 3

Design the UPS system by indicating its appropriate capacity (in kVA) and the proper battery rating for the UPS.

(14 marks)

**– END OF QUESTIONS –**

**FINAL EXAMINATION**

SEMESTER/SESSION : SEM II/ 2012/2013

PROGRAMME : BEF

COURSE NAME : INDUSTRIAL POWER SYSTEMS

COURSE CODE : BEF 44903

**TABLE Q1(c)**

Load description	3 $\phi$ / 1 $\phi$	Duty N or S	Motor rating (kW)	Operating motor power (kW)	Power Factor	Efficiency (%)
Hoist system	3	N	50	42	0.80	88
Cooling tower fan	3	S	20	17	0.86	92
Heater	3	N	15	-	-	-
Fan coil	1	N	2	1.6	0.90	82
Water pump	3	N	18	15	0.82	70
Extract fan	1	N	1.5	1.2	0.87	90
Compressor	1	N	1.5	1.3	0.88	82
Future pump	3	N	10	8.8	0.90	80

**TABLE Q1(d)(1)**

Rating factors for variation in ambient air temperature:

Air Temp. (°C)	20	25	30	35	40	45	50	55
Rating Factor	1.81	1.41	1.10	1.05	1.00	0.95	0.89	0.84

**TABLE Q1(d)(2)**

Rating factors for multi-core cables laid on open racks in air:

No. of racks	No. of cables per rack				
	1	2	3	6	9
1	1.00	0.84	0.80	0.75	0.73
2	1.00	0.80	0.76	0.71	0.69
3	1.00	0.78	0.74	0.70	0.68
6	1.00	0.76	0.72	0.68	0.66

## FINAL EXAMINATION

SEMESTER/SESSION : SEM II/ 2012/2013

PROGRAMME : BEF

COURSE NAME : INDUSTRIAL POWER SYSTEMS

COURSE CODE : BEF 44903

### TABLE Q1(d)(3)

**TABLE 4D2A – Multicore 70 °C thermoplastic insulated and thermoplastic sheathed cables,  
Non-armoured  
(COPPER CONDUCTORS)**

CURRENT-CARRYING CAPACITY (amperes):

Ambient temperature: 30 °C  
Conductor operating temperature: 70 °C

Conductor cross-sectional area	Reference Method A (enclosed in conduit in thermally insulating wall etc.)		Reference Method B (enclosed in conduit on a wall or in trunking etc.)		Reference Method C (clipped directly)		Reference Method E (in free air or on a perforated cable tray etc. horizontal or vertical)	
	1 two-core cable*, single-phase a.c. or d.c.	1 three-core cable* or 1 four-core cable, three-phase a.c.	1 two-core cable*, single-phase a.c. or d.c.	1 three-core cable* or 1 four-core cable, three-phase a.c.	1 two-core cable*, single-phase a.c. or d.c.	1 three-core cable* or 1 four-core cable, three-phase a.c.	1 two-core cable*, single-phase a.c. or d.c.	1 three-core cable* or 1 four-core cable, three-phase a.c.
1	2	3	4	5	6	7	8	9
(mm <sup>2</sup> )	(A)	(A)	(A)	(A)	(A)	(A)	(A)	(A)
1	11	10	13	11.5	15	13.5	17	14.5
1.5	14	13	16.5	15	19.5	17.5	22	18.5
2.5	18.5	17.5	23	20	27	24	30	25
4	25	23	30	27	36	32	40	34
6	32	29	38	34	46	41	51	43
10	43	39	52	46	63	57	70	60
16	57	52	69	62	85	76	94	80
25	75	68	90	80	112	96	119	101
35	92	83	111	99	138	119	148	126
50	110	99	133	118	168	144	180	153
70	139	125	168	149	213	184	232	196
95	167	150	201	179	258	223	282	238
120	192	172	232	206	299	259	328	276
150	219	196	258	225	344	299	379	319
185	248	223	294	255	392	341	434	364
240	291	261	344	297	461	403	514	430
300	334	298	394	339	530	464	593	497
400	-	-	470	402	634	557	715	597

\* with or without a protective conductor

**FINAL EXAMINATION**

SEMESTER/SESSION : SEM II/ 2012/2013

PROGRAMME : BEF

COURSE NAME : INDUSTRIAL POWER SYSTEMS

COURSE CODE : BEF 44903

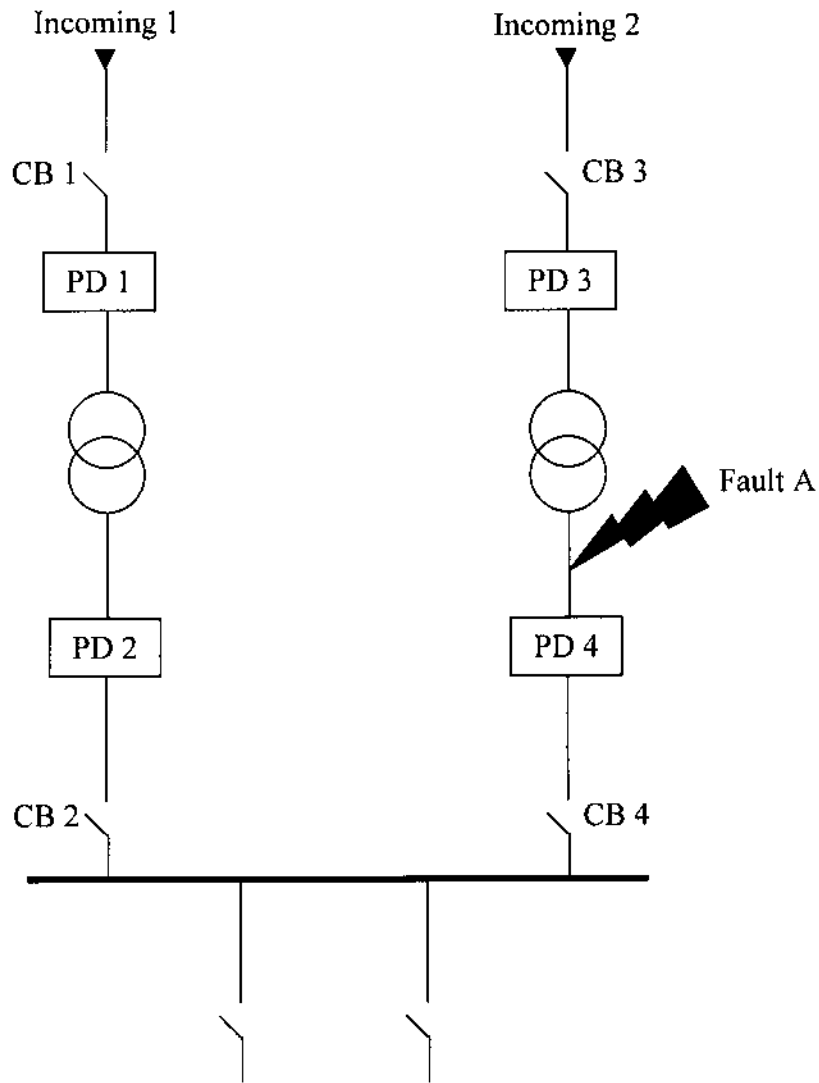

**FIGURE Q2(b)**

FINAL EXAMINATION

SEMESTER/SESSION : SEM II/ 2012/2013

PROGRAMME : BEF

COURSE NAME : INDUSTRIAL POWER SYSTEMS

COURSE CODE : BEF 44903

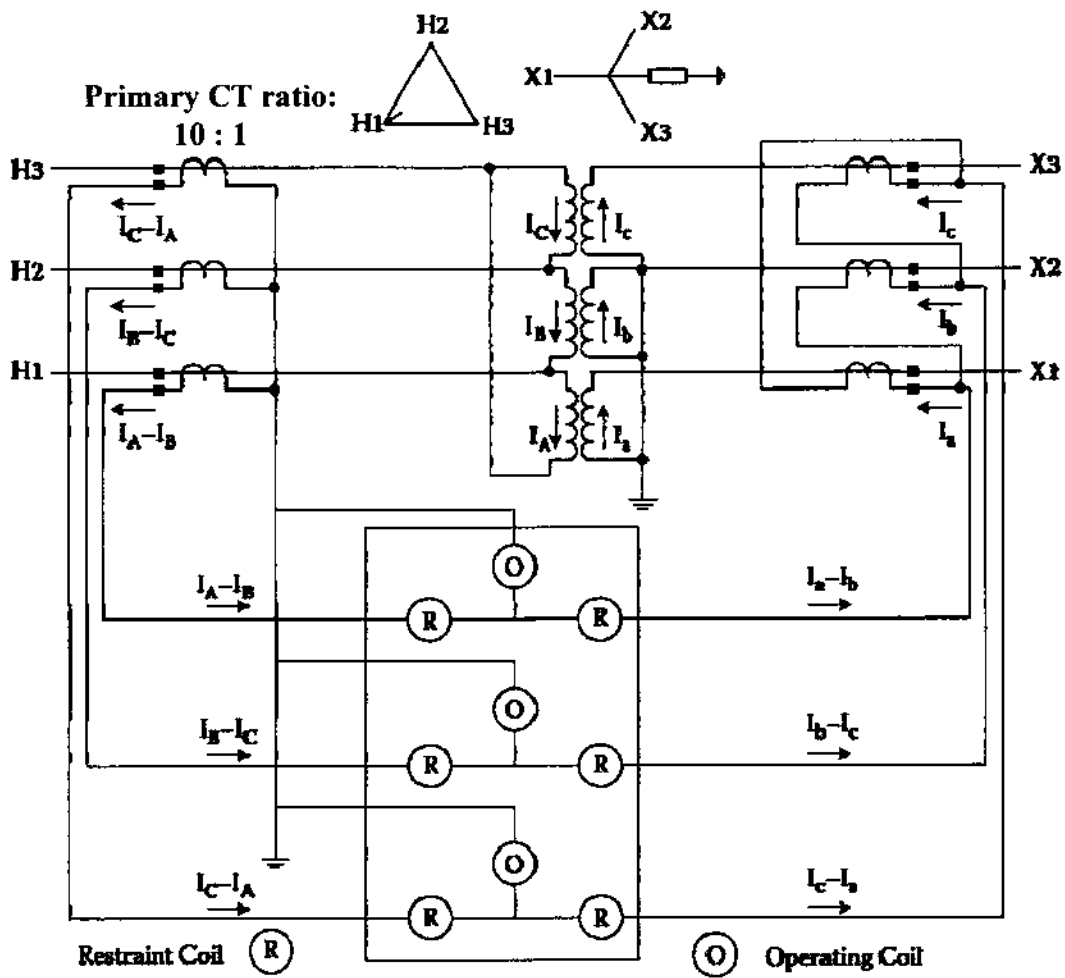

FIGURE Q2(c)



**FINAL EXAMINATION**

SEMESTER/SESSION : SEM II/ 2012/2013  
 COURSE NAME : INDUSTRIAL POWER SYSTEMS

PROGRAMME : BEF  
 COURSE CODE : BEF 44903

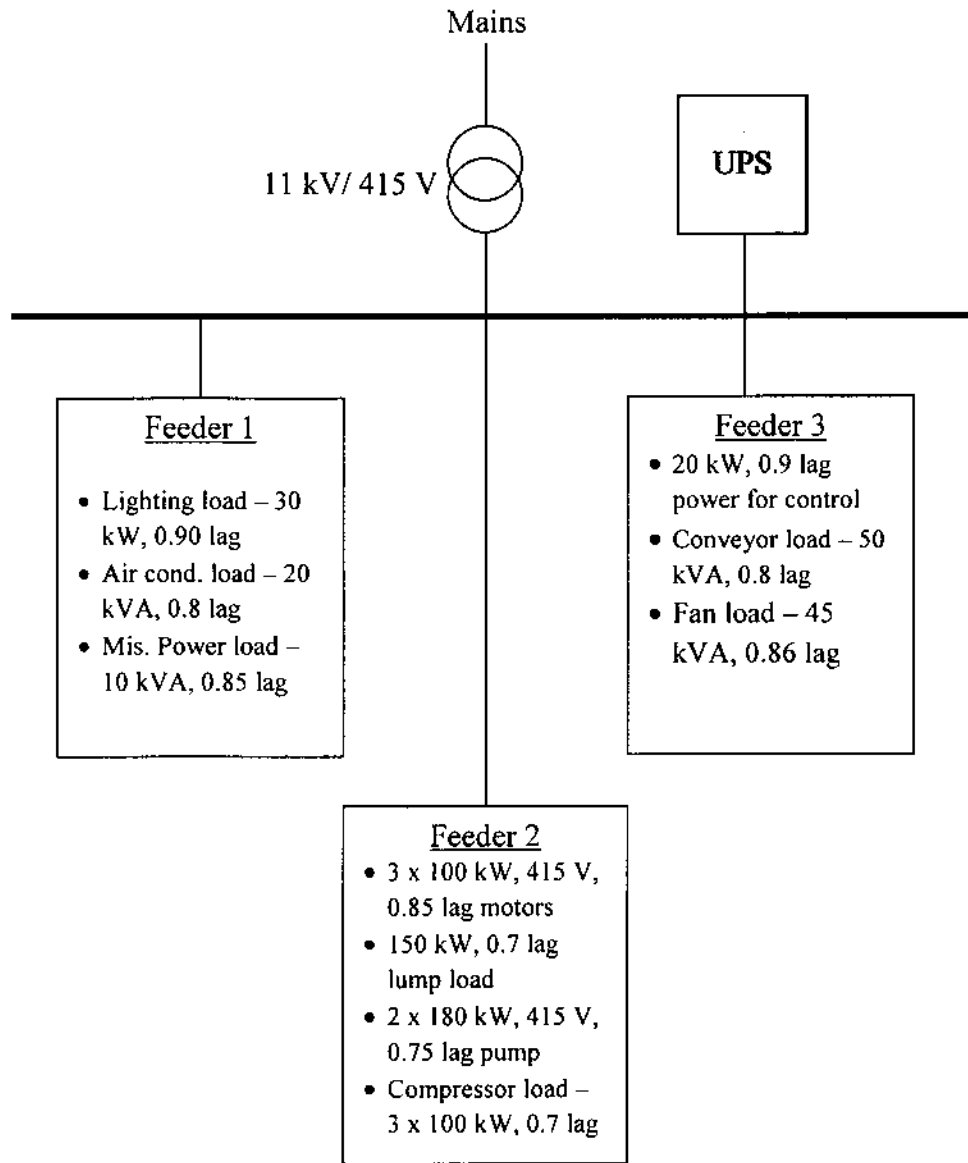

**FIGURE Q4(c)**

**FINAL EXAMINATION**

SEMESTER/SESSION : SEM II/ 2012/2013

PROGRAMME : BEF

COURSE NAME : INDUSTRIAL POWER SYSTEMS

COURSE CODE : BEF 44903

**APPENDIX A**

The minimum cable size due to short circuit temperature rise:

$$A = \frac{\sqrt{I_{sc}^2 t}}{K}$$

where,

 $A$  = Minimum required cross section area in  $\text{mm}^2$  $t$  = The duration of the short circuit in second $K$  = Short circuit temperature rise constantThe temperature rise constant ( $K$ ) according to IEC 60364-5-54:

$$K = 226 \sqrt{\ln \left( 1 + \frac{T_2 - T_1}{234.5 + T_1} \right)} \dots \dots (\text{for copper conductors})$$

$$K = 148 \sqrt{\ln \left( 1 + \frac{T_2 - T_1}{228.1 + T_1} \right)} \dots \dots (\text{for aluminium conductors})$$

where,

 $T_1$  = the initial conductor temperature in  $^{\circ}\text{C}$  $T_2$  = the final conductor temperature in  $^{\circ}\text{C}$ Table A1: Boundary conditions of initial ( $T_1$ ) and final ( $T_2$ ) temperature for different insulation:

Insulation material	Final temperature, $T_2$ ( $^{\circ}\text{C}$ )	Initial temperature, $T_1$ ( $^{\circ}\text{C}$ )
PVC	150	70
Butyl Rubber	220	85
XLPE/EPR	250	90

**Standard Cable Size ( $\text{mm}^2$ ):**

1, 1.5, 2.5, 4, 6, 10, 16, 25, 35, 50, 70, 95, 120, 150, 185, 240, 300, 400.