



UNIVERSITI TUN HUSSEIN ONN MALAYSIA

**FINAL EXAMINATION
SEMESTER II
SESSION 2011/2012**

COURSE NAME : FUZZY CONTROL SYSTEM
COURSE CODE : BER 4233
PROGRAMME : BEE
EXAMINATION DATE : JUNE 2012
DURATION : 2 ½ HOURS
INSTRUCTION : ANSWER **FOUR (4)** QUESTIONS ONLY

THIS PAPER CONSISTS OF **SIX (6)** PAGES

- Q1** A MISO fuzzy control system is applied for a cruise control system that is called a fuzzy cruise control system. A fuzzy cruise control system has function to maintain a constant vehicle speed in spite of neverending changes in road grade, wind resistance, and other variables. The controller does this by comparing the commanded speed with the actual speed. The difference between commanded and actual speed is error. Then, the change in error is the difference in error from one sample period to the next. The speed of the vehicle is controlled through controlling the throttle angle. Error (e) and change in error (de) as input variables have three fuzzy sets, they are Negative, Zero, and Positive respectively. While, throttle angle as output variable has five fuzzy sets, they are Large Negative, Negative, Zero, Positive, and Large Positive. Rule tabulation and fuzzy sets graph of each variables are represented in Table Q1 and Figure Q1. If error (e) and change in error (de) value are -4.5 and -4.5 respectively:
- Create the possible rule fire based on min method related with e and de value (4 marks)
 - Determine each rule quantification (18 marks)
 - Draw the clipping of the rule quantification result (1 marks)
 - Calculate the crisp value of throttle angle using COG defuzzyfication (2 marks)
- Q2**
- Differentiate between crisp and fuzzy logic (7 marks)
 - Describe two senses of fuzzy logic (5 marks)
 - Draw a fuzzy controller block and briefly explain each element of the block (8 marks)
 - Explain why input and output variables are very important in designing a fuzzy Control system (5 marks)
- Q3**
- Consider two fuzzy subsets of set $X, X = \{1, 2, 3, 4, 5, 6, 7, 8, 9, 10\}$, referred to as A and B as shown in Figure Q3. Calculate: support A, support B, core A, core B, cardinality A, cardinality B, compliment A, compliment B, union A and B, intersection A and B (16 marks)
 - MISO Fuzzy controller has triangular membership function with each universe discourse as below:
 - Heater current (hc):
 - Low (L): $[0, 5, 10]$

- Medium (M): [4, 8, 12]
- High (H): [10, 15, 20]
- Cool water flow (cwf):
 - Low (L): [0, 4, 8]
 - Middle (Ml): [2, 5, 8]
 - Hard (H): [4, 7, 10]
- Water output temperature (wot):
 - Cool (C): [0, 8, 16]
 - Warm (W): [4, 10, 22]
 - Hot (H): [20, 25, 30]

Derive the formulation for Heater current Low (L), Cool water flow Middle (Ml) and Water output temperature Hot (H)

(9 marks)

- Q4**
- (a) Differentiate between neural network and computer. (5 marks)
 - (b) Compare learning of neural network. (5 marks)
 - (c) Explain what mean of neural network training or learning. (5 marks)
 - (d) Explain why neural network must be train before apply to solve the problem. (5 marks)
 - (e) Differentiate between neural network and fuzzy logic. (5 marks)

Q5 Develop weights updating formulation for first iteration of MOBP neural network shown in Figure Q1. Where η is network learning rate, α is momentum, network weights and weight increments are w_1, w_2, \dots, w_{12} and $\Delta w_1, \Delta w_2, \dots, \Delta w_{12}$ respectively. Input variables are x_1, x_2, \dots, x_7 and output variable is y . Learning target is t . Activation functions for hidden layer and output layer neurons are $f(net) = \frac{1}{1 + e^{-net}}$, while input layer neurons have linear activation function.

(25 marks)

Q6 A MLPWLS neural network is represented in Figure Q3. The networks have weights initial condition are: $w_1 = 0.01$, $w_2 = -0.01$ and $v = 0.11$. Activation function for hidden and output layer is $y_{pk} = C \left[\frac{e^{c \cdot net_{pk}}}{1 + e^{c \cdot net_{pk}}} - 0.5 \right]$ with $C = 1.2$, $c = 0.2$, α_{cp} for keeping weight increment in range $[-0.5 \ 0.5]$, $Q_w = Q_v = 0.2$, $\sigma = 0.1$ and $\alpha = 0.75$. Neural network is used to evaluate OR GATE for input $x_1 = 1$, $x_2 = 1$ and target $t = 1$.

- (a) Determine the value of each weight after one iteration (22 marks)
- (b) Calculate and draw MSE graph (3 marks)

FINAL EXAMINATION

SEMESTER/SESSION : II / 2011/2012
 COURSE : FUZZY CONTROL SYSTEM

PROGRAMME : BEE
 COURSE CODE : BER 4233

Table Q1

Throttle angle		Change in error (de)		
		Negative	Zero	Positive
Error (e)	Negative	Large Negative	Negative	Zero
	Zero	Negative	Zero	Positive
	Positive	Zero	Positive	Large Positive

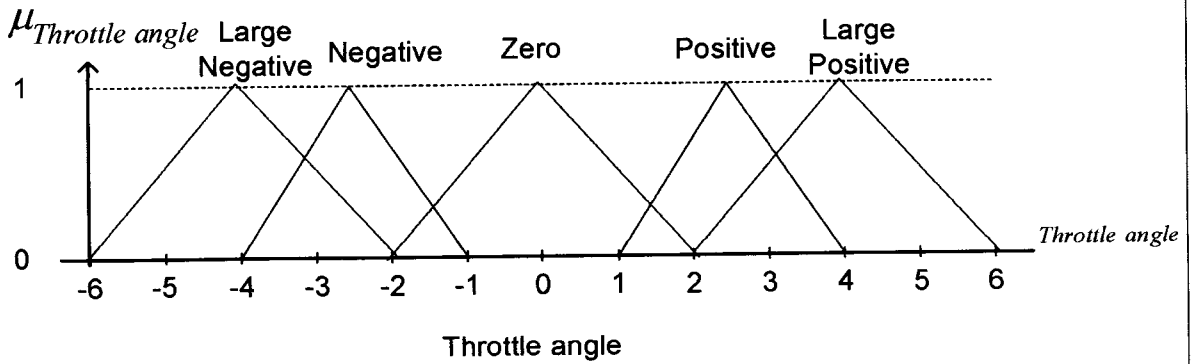
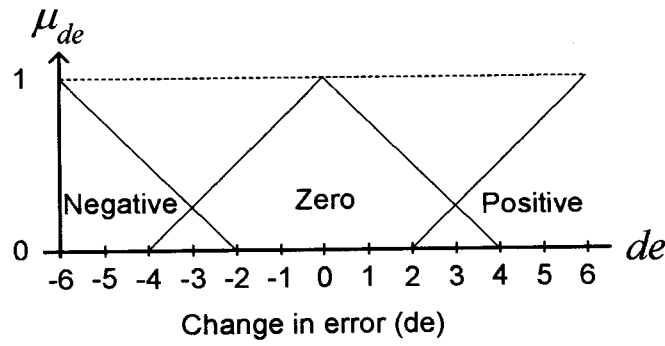
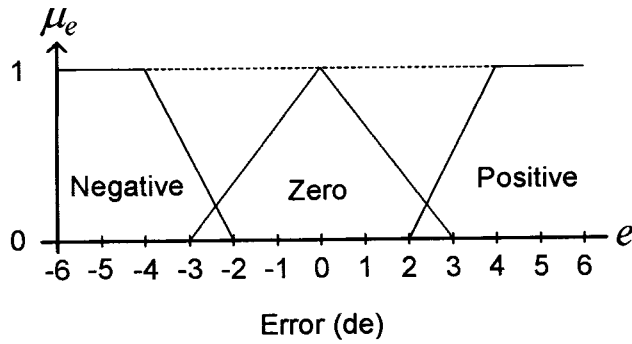

FIGURE Q1

FINAL EXAMINATION

SEMESTER/SESSION : II / 2011/2012
 COURSE : FUZZY CONTROL SYSTEM

PROGRAMME : BEE
 COURSE CODE : BER 4233

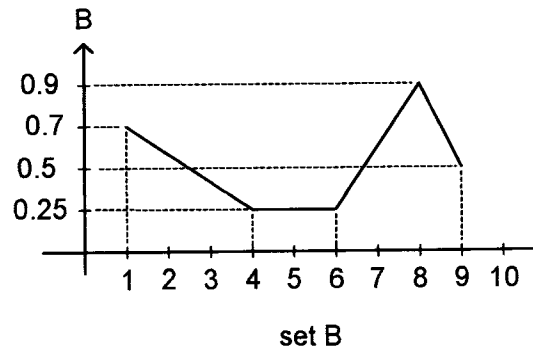
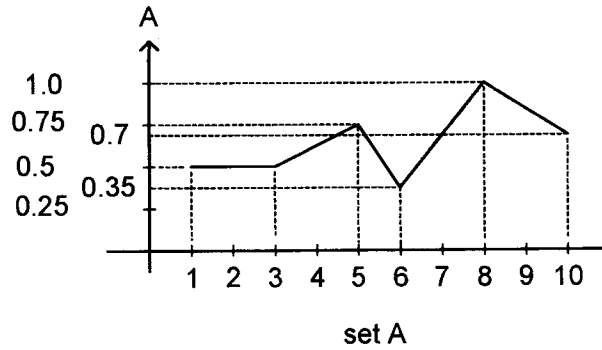

FIGURE Q3

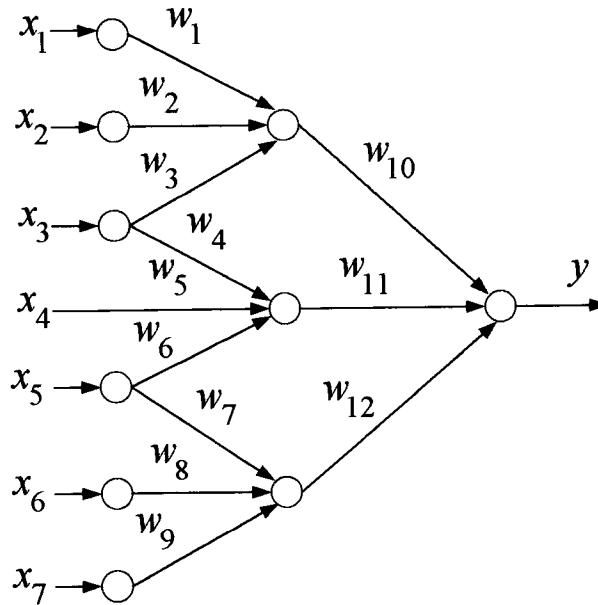

FIGURE Q5

FINAL EXAMINATION

SEMESTER/SESSION : II / 2011/2012
COURSE : FUZZY CONTROL SYSTEM

PROGRAMME : BEE
COURSE CODE : BER 4233

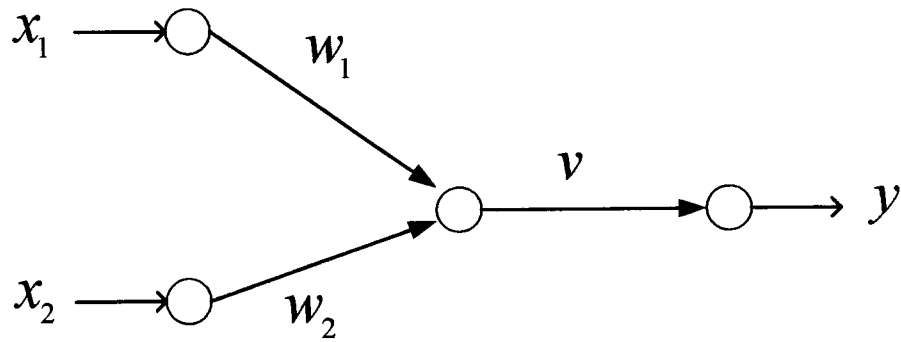

FIGURE Q6