



UNIVERSITI TUN HUSSEIN ONN MALAYSIA

FINAL EXAMINATION SEMESTER I SESSION 2010/11

COURSE NAME : DIGITAL ELECTRONICS
COURSE CODE : BEX 21103/BEE 2233
PROGRAMME : 2 BEE
EXAMINATION DATE : NOVEMBER/DISEMBER 2010
DURATION : 2 HOURS 30 MINUTES
INSTRUCTION : ANSWER ALL QUESTIONS

THIS PAPER CONSISTS OF SIX (6) PAGES

- Q1** (a) Define the differences between analog and digital quantities. Give an example that is combination of both analog and digital system. (5 marks)

- (b) Identify whether the following expression is True or False;

$$(A+B+\bar{C}) \cdot (A+\bar{B}+C) \cdot (\bar{A}+B+C) \cdot (\bar{A}+\bar{B}+\bar{C}) = A \oplus B \oplus C$$

(5 marks)

- (c) Give the simplified SOP of the following expression;

$$f(A,B,C,D) = \sum m(4,8,9,12,13,14) + \sum d(0,5,10,15)$$

(5 marks)

- Q2** (a) How does an exclusive-OR gate can be used to detect bit equality? (4 marks)

- (b) **Figure Q2 (b)** shows a combinational logic circuit. Use Boolean Theorem to find the simplified expression. (5 marks)

- (c) Interpret the following logic using only NOR gates;

$$W = P \cdot \overline{\overline{Q} \cdot \overline{R} \cdot S}$$

(6 marks)

- Q3** (a) Illustrate the basic operation of a demultiplexer by the aid of a diagram. (3 marks)

- (b) **Figure Q3 (b)** shows a 2-bit full adder. Demonstrate the generated carry and propagated carry by using the diagram. (4 marks)

- (c) **Figure Q3 (c)** shows a 2-to-4 decoder. How it can be cascaded to operate as a 4-to-16 decoder circuit? (8 marks)

- Q4** (a) **Figure Q4 (a)** shows a SC flip-flop. Draw the output waveform of the flip-flop (Q). Assume initially $Q = 0$ (6 marks)
- (b) **Figure Q4 (b)** shows a state transition diagram of a counter. Develop the excitation table and K-map for each input. (9 marks)
- Q5** **Figure Q5** shows a shaft encoder system that measures the angle rotation in rotating machine. The encoder consists of a disc with the fixed pattern shown in **Figure Q5** rotating in the anti-clockwise direction. Three light sources are used to shine light through each of three concentric rings on the encoder and are detected by the three photo detectors on the other side of the encoder disc. The most inner ring encodes the least significant bit (LSB) of the angle. In this way, one revolution is divided into 8 separate segments where segment 0 is from 0° to 45° , segment 1 is from 45° to 90° , and so on up to and including segment 7. Light cannot penetrate through the shaded region of the disc. Each photo detector produces logic '1' if light is detected and logic '0' otherwise.
- (a) Derive the truth table showing the segment and the corresponding signals G2, G1 and G0. (8 marks)
- (b) Determine the simplest Boolean expressions for A2, A1 and A0. (9 marks)
- (c) Draw the complete circuit using any logic gates. (3 marks)
- Q6** (a) Differentiate the characteristic of four main categories of 4-bit registers in terms of data propagation. (5 marks)
- (b) **Figure Q6 (c)** shows the MOD-8 synchronous up counter. Modify the circuit by adding appropriate combinational logic gates to become a MOD-8 up/down counter. (7 marks)
- (c) The input frequency of a clock generator system is 48 kHz. The system is required to generate two frequencies 12 kHz and 4 kHz at its outputs. Propose an arrangement for frequency division by using JK flip-flop. (8 marks)

FINAL EXAMINATION

SEMESTER/SESSION : SEM 1/2010/11
 COURSE : DIGITAL ELECTRONICS

PROGRAMME : 2 BEE
 COURSE CODE : BEX21103/BEE2233

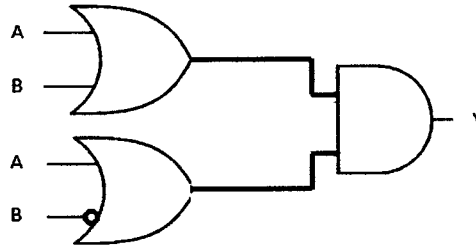

Figure Q2 (b)

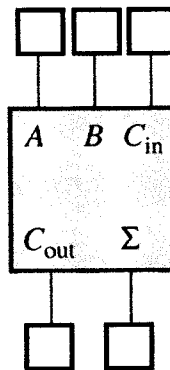

Figure Q3 (b)

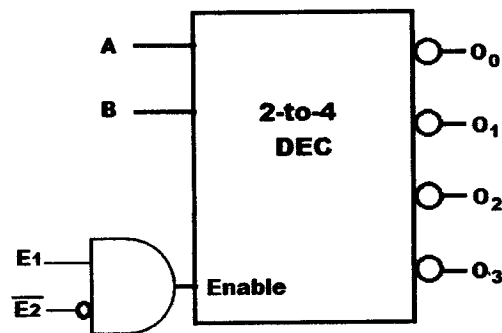

Figure Q3 (c)

FINAL EXAMINATION

SEMESTER/SESSION	: SEM 1/2010/11	PROGRAMME	: 2 BEE
COURSE	: DIGITAL ELECTRONICS	COURSE CODE	: BEX21103/BEE2233

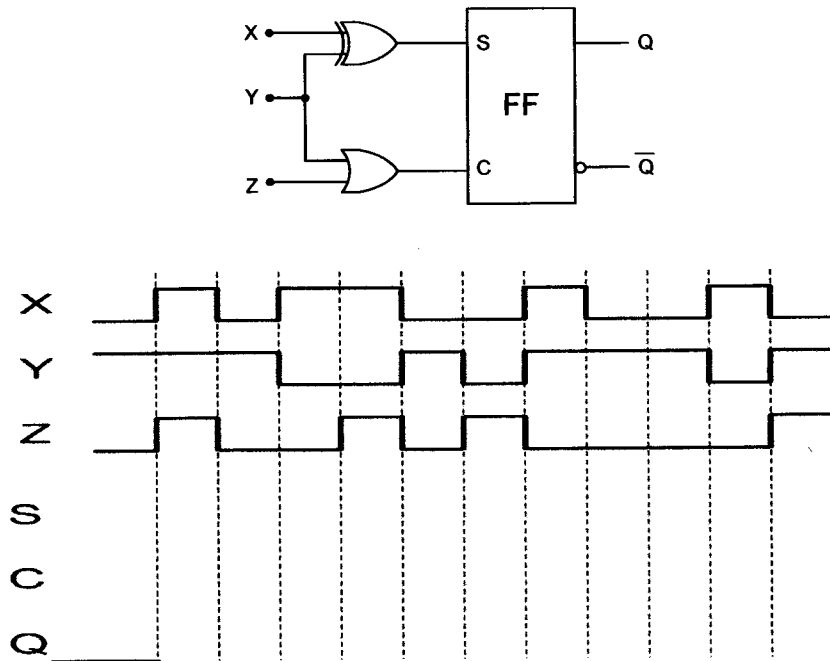

Figure Q4 (a)

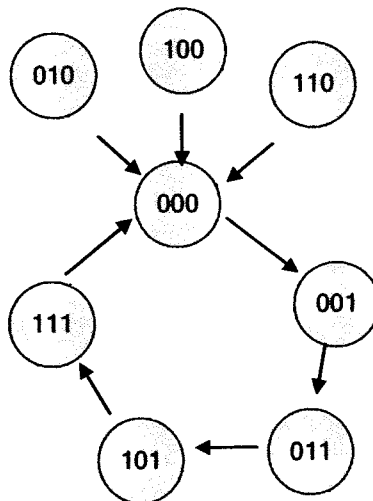

Figure Q4 (b)

FINAL EXAMINATION

SEMESTER/SESSION : SEM 1/2010/11 PROGRAMME : 2 BEE
 COURSE : DIGITAL ELECTRONICS COURSE CODE : BEX21103/BEE2233

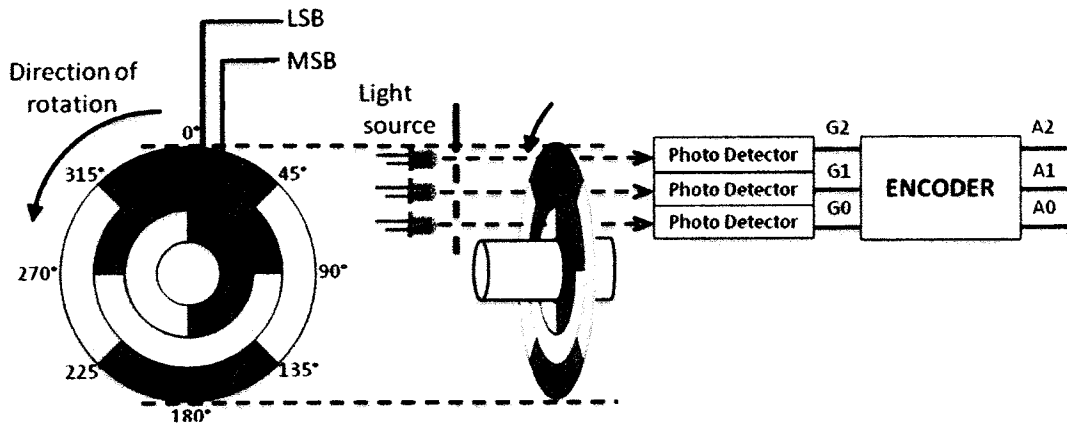

Figure Q5

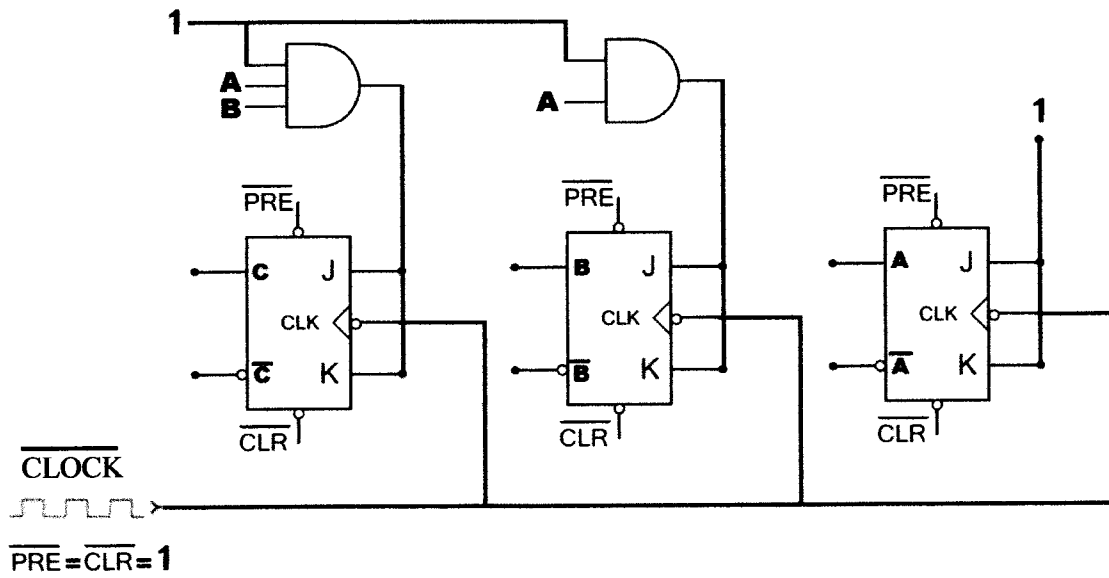

Figure Q6 (c)