



UNIVERSITI TUN HUSSEIN ONN MALAYSIA

**FINAL EXAMINATION
SEMESTER II
SESSION 2010/2011**

COURSE : ELECTRONIC CONTROL
COURSE CODE : BEM 4843
PROGRAMME : BEE
EXAMINATION DATE : APRIL / MAY 2011
DURATION : 2 HOUR 30 MINUTES
INSTRUCTION : ANSWER **FOUR (4)** QUESTIONS ONLY

THIS PAPER CONSISTS OF ELEVEN (11) PAGES

Q1 The diagram in Figure Q1(a) shows a system composed of a storage tank, an inlet pipe with a manual control valve, and an outlet pipe. A continuous flow of water from a natural spring enters the tank at the inlet, and water flows from the outlet pipe to the irrigation system. The process variable that is maintained in the tank is the water level. Ideally, the flow control valve setting and the size of the outlet pipe are exactly the same. When this occurs, the water level in the tank remains the same. Therefore the process reaches a steady-state condition, or is said to be *balanced*.

The problem with this design is that any change or disturbance will upset the balance. For example, a substantial rainfall may occur. Since there is more water entering the tank than exiting, the level will rise. If this situation is not corrected, the tank will eventually overflow. Excessive evaporation will also upset the balance. If it occurs over a prolonged period of time, the water level in the tank may become unacceptably low. A human operator who periodically inspects the tank can change the control valve setting to compensate for these disturbances.

The reservoir system is modified in order to perform automatic control by replacing the manually controlled valve with an adjustable valve connected to a float, as shown in Figure Q1(b). The valve, the float, and the linkage mechanism provide the feedback loop.

If the level of the water in the tank goes up, the float is pushed upward; if the level goes down, the float moves downward. The float is connected to the inlet valve by a mechanical linkage. As the water level rises, the float moves upward, pushing on the lever and closing the valve, thus reduce the water flow into the tank. If the water level lowers, the float moves downward, pulling on the lever and opening the valve, thus admitting more water into the tank. To adjust for a desired level of water in the tank, the float is moved up or down on the float rod A.

Determine the following:

- (a) Controlled variable in this process. (2 marks)
- (b) Manipulated variable in this process. (2 marks)
- (c) Set point in this process. (2 marks)
- (d) Measured variable in this process. (2 marks)
- (e) Draw the open-loop block diagram that shows elements, input/output signals, and signal direction as shown in Figure Q1(a). (7 marks)
- (f) Draw the closed-loop block diagram that shows elements, input/output signals, and signal direction as shown in Figure Q1(b). (10 marks)

- Q2** (a) The op-amp as shown in Figure Q2(a) is capable of comparing the voltage applied to one input to the voltage applied to the other input. Calculate the output voltage (V_{out}) in Table Q2(a).
(7 marks)
- (b) Figure Q2(b) shows an inverting op-amp. Calculate the output voltage (V_{out}) in Table Q2(b) by applying the listed input voltages (V_{in}).
(8 marks)
- (c) Figure Q2(c) shows a summing amplifier with the ability of adding the algebraic sum of all the input voltages. Calculate the output voltage (V_{out}) in Table Q2(c) by applying the listed input voltages (V_1 , V_2 and V_3).
(10 marks)
- Q3** (a) Calculate the differential gap percentage of the On-Off controller if a full temperature control range is 60°C and the differential gap is 10°C .
(3 marks)
- (b) If the output of the controller changes by 25% when the applied signal to its input is 10%. Calculate the gain of the controller.
(3 marks)
- (c) (i) What is the definition of proportional band of a controller?
(2 marks)
- (ii) What is the relation between the gain and proportional band of a controller?
(2 marks)
- (d) (i) Figure Q3(d)(i) shows PID control system of a robot arm. Explain the operation of the system.
(10 marks)
- (ii) The command signal and feedback signal is shown in Figure Q3(d)(ii). Draw the derivative output of the controller.
(5 marks)

- Q4** (a) Consider an elevator with a weight of 700 kg which can carry up to 6 passengers each having a weight of 80 kg as shown in Figure Q4(a). A DC motor is used to raise the elevator through the drum of 2 m in diameter and cable with a full load from the ground floor to the third floor, 9 m higher, in 30 s. Given acceleration due to gravity $g = 9.81 \text{ m/s}^2$.
- (i) Calculate the motor torque that required. (7 marks)
 - (ii) Calculate the total energy that needed. (3 marks)
 - (iii) For safety reason, the motor power must be 4 (four) times equal to the required power. Calculate the required motor horse power. (6 marks)
 - (iv) Given the motor efficiency is 90%. Calculate the wattage consumed by the motor. (3 marks)
- (b) Briefly explain 3 (three) methods to control the speed of DC shunt motors. (6 marks)
- Q5** (a) List and define three (3) factors to determine the speed of an AC motor. (6 marks)
- (b) Find the speed of a 12-pole motor when 50 Hz frequency is applied. (5 marks)
 - (c) Calculate the percent slip of a two-phase motor that has a synchronous speed of 4550 RPM and a rotor speed of 4270 RPM. (5 marks)
 - (d) Calculate the speed of stepper motor in RPM that operates at a step angle of 12 degrees with the stepping rate of 320 degrees. (5 marks)
 - (e) List two (2) advantages of DC drive over AC drive. (4 marks)

- Q6** (a) (i) Whenever fast moving object is sensed, the response time of the sensor becomes important. What is the sensor response time?
(3 marks)
- (ii) In the packaging industry a photoelectric sensor is used to detect boxes on the conveyor as shown in Figure Q6(a)(ii). The dimension of the boxes is 5 cm x 5 cm x 3 cm (length x width x height). The width of the light beam is 1 cm. The speed of the motor is 90 rpm. The diameter of the roller is 20 cm. Calculate the required sensor response time.
(10 marks)
- (b) When a large resistive load is controlled by a Normally Closed (NC) contact, a snubber is required to prevent arcing when the contacts open.
- (i) Explain the operation of the snubber.
(3 marks)
- (ii) Draw the NC contact with the snubber and resistive load.
(3 marks)
- (iii) Calculate the value of the components of a snubber for NC contact if the voltage value across the contact when they are opened is 50V and the holding current value of the load is 2A.
(6 marks)

FINAL EXAMINATION

SEMESTER/SESSION : SEM II / 2010/2011

PROGRAMME : BEE

COURSE : ELECTRONIC CONTROL

COURSE : BEM 4843

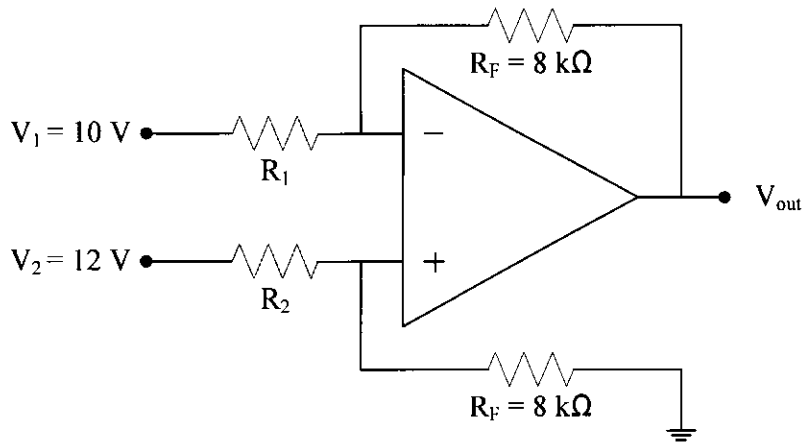

Figure Q2(a)

Table Q2(a)

No.	Input Resistance (kΩ)		Output Voltage (V _{out})
	R ₁	R ₂	
(i)	1	2	
(ii)	3	2	
(iii)	3	4	
(iv)	4	2	
(v)	5	3	
(vi)	3	6	

FINAL EXAMINATION

SEMESTER/SESSION : SEM II / 2010/2011
 COURSE : ELECTRONIC CONTROL

PROGRAMME : BEE
 COURSE : BEM 4843

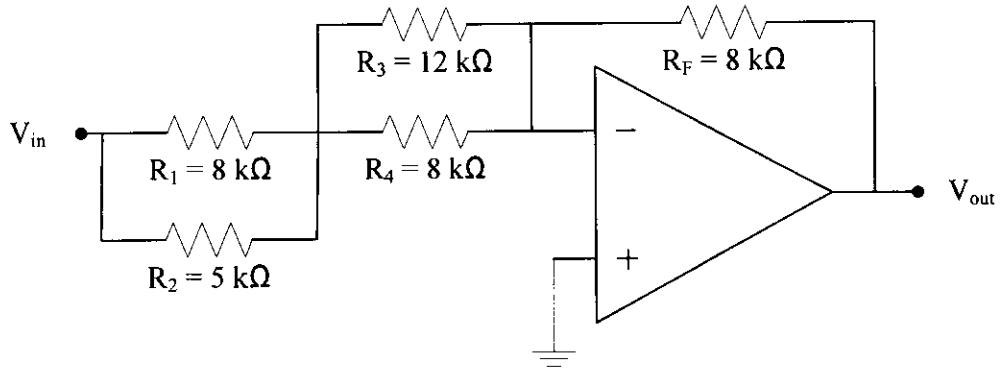

Figure Q2(b)

Table Q2(b)

No.	Input Voltage (V_{in})	Output Voltage (V_{out})
(i)	+ 5.46	
(ii)	- 1.25	
(iii)	- 6.42	
(iv)	+ 0.88	
(v)	+ 4.90	
(vi)	- 5.00	

FINAL EXAMINATION

SEMESTER/SESSION : SEM II / 2010/2011
 COURSE : ELECTRONIC CONTROL

PROGRAMME : BEE
 COURSE : BEM 4843

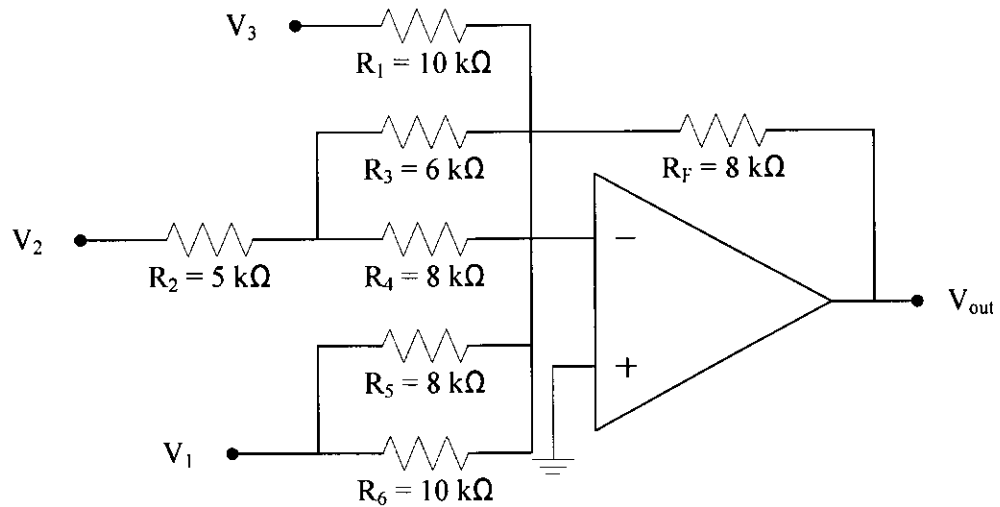

Figure Q2(c)

Table Q2(c)

No.	Input Voltage (V_{in})			Output Voltage (V_{out})
	V_1	V_2	V_3	
(i)	+1	+2	+4	
(ii)	+3	-2	-1	
(iii)	+3	-4	-3	
(iv)	-3	+4	+5	
(v)	+5	+1	-2	
(vi)	+2	-1	-3	

FINAL EXAMINATION

SEMESTER/SESSION : SEM II / 2010/2011
 COURSE : ELECTRONIC CONTROL

PROGRAMME : BEE
 COURSE : BEM 4843

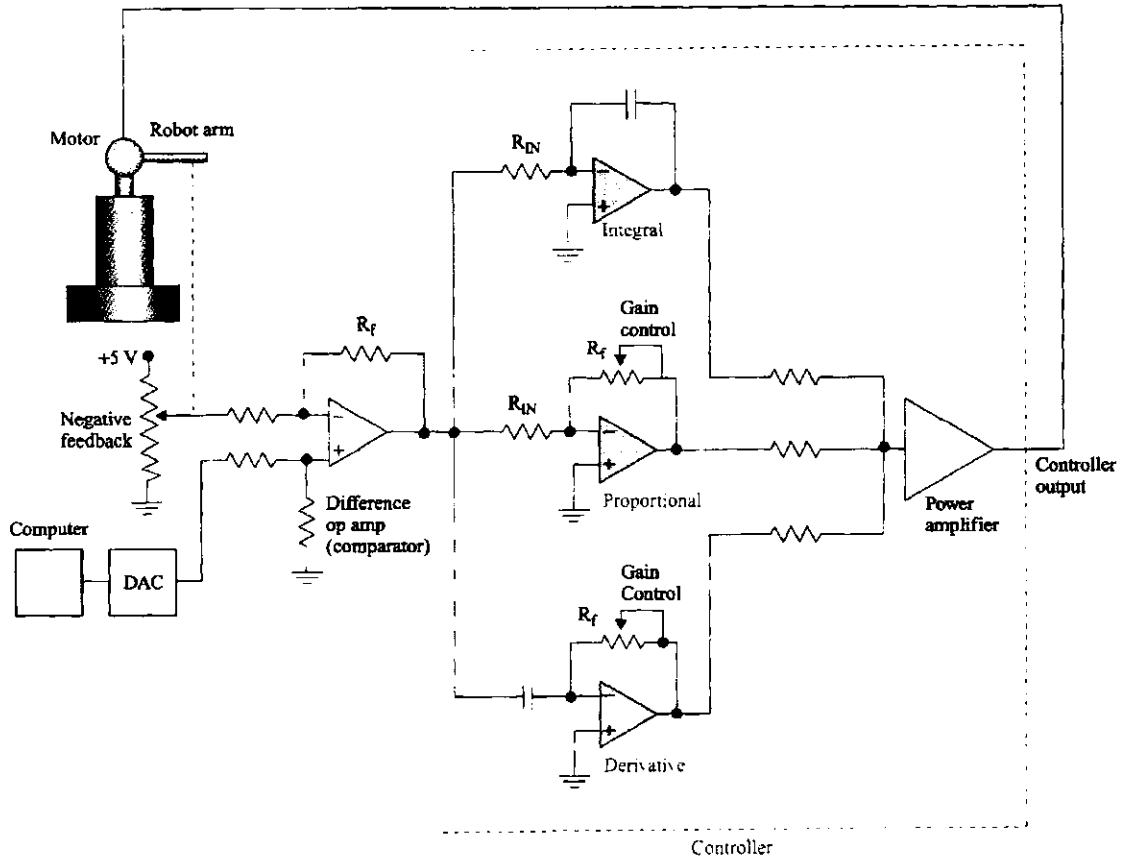

Figure Q3(d)(i)

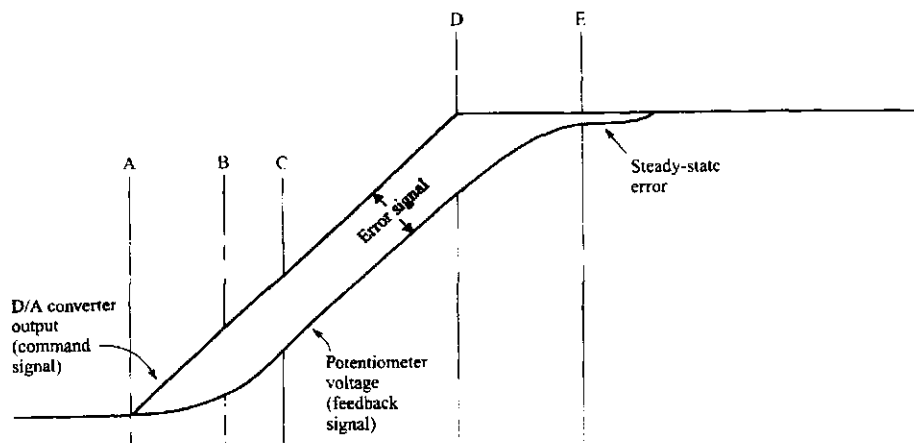

Figure Q3(d)(ii)

FINAL EXAMINATION

SEMESTER/SESSION : SEM II / 2010/2011
COURSE : ELECTRONIC CONTROL

PROGRAMME : BEE
COURSE : BEM 4843

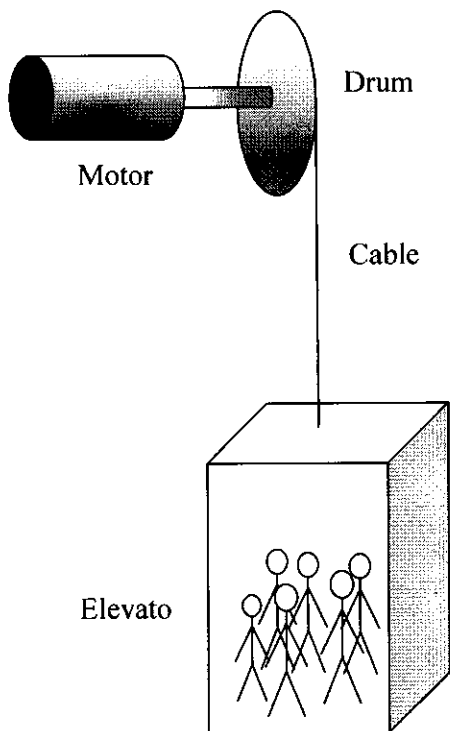

Figure Q4(a)

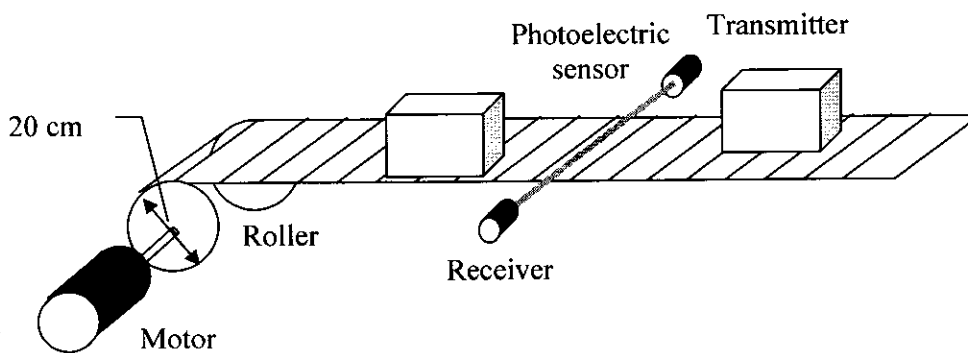

Figure Q6(a)(ii)