

**CONFIDENTIAL**



**UNIVERSITI TUN HUSSEIN ONN MALAYSIA**

**FINAL EXAMINATION  
SEMESTER II  
SESSION 2010/2011**

**COURSE : CONTROL SYSTEM**

**COURSE CODE : BEX 31603/ BEE 3143**

**PROGRAMME : BACHELOR OF ELECTRICAL  
ENGINEERING WITH HONOURS**

**EXAMINATION DATE : APRIL/ MAY 2011**

**DURATION : 2 HOURS 30 MINUTES**

**INSTRUCTION : ANSWER FOUR (4) QUESTIONS ONLY**

**THIS PAPER CONSISTS OF NINE (9) PAGES**

**CONFIDENTIAL**

- Q1** (a) With a proper block diagram, explain briefly an open loop control system and closed loop control system. (5 marks)
- (b) Figure Q1(b) shows a cross-section of a Digital Single Lens Reflex (DSLR) camera. Based on the diagram, explain the basic operation of the camera. (6 marks)
- (c) From your answer in Q1(b), identify the type of control system implemented in the camera and generate the control system block diagram for the DSLR camera. (8 marks)
- (d) List three (3) advantages and three (3) disadvantages of DSLR camera. (6 marks)

- Q2** (a) Determine the transfer function  $\frac{C(s)}{R(s)}$  for a system shown in Figure Q2(a) using block diagram reduction technique. (13 marks)
- (b) To design an engine vibration control system, a model of an engine mounted to the car's body is developed as shown in Figure Q2(b).
- (i) Derive the differential equation(s) representing the system. (6 marks)
- (ii) Derive the transfer function  $\frac{X_b(s)}{X_e(s)}$ . (6 marks)

- Q3** (a) The closed loop transfer function for unity feedback system with negative feedback is given by:

$$\frac{C(s)}{R(s)} = \frac{\omega_n^2}{s^2 + 5s + \omega_n^2}$$

The poles of  $\frac{C(s)}{R(s)}$  for underdamped response are given by:

$$s_1, s_2 = \frac{-2\zeta\omega_n \pm \sqrt{4\zeta^2\omega_n^2 - 4\omega_n^2}}{2}$$

The s-plane plot for the system is shown in Figure Q3(a).

- (i) Determine the value of  $\alpha$ . (4 marks)
- (ii) Calculate rise time,  $T_r$ . (1 marks)
- (iii) Calculate peak time,  $T_p$ . (1 marks)
- (iv) Calculate overshoot. (2 marks)
- (v) If the system is designed to have  $\theta = 60^\circ$ , determine the percentage of increasing overshoot compared to the results in Q3(a)(iv). (4 marks)

(b) Figure Q3(b) shows a unity feedback system with:

$$G(s) = \frac{120}{s^4 + 14s^3 + 71s^2 + 154s + 120}$$

where  $K=1$ .

- (i) List down three (3) common test signal and its Laplace representation. (3 marks)
- (ii) Identify the system type. (1 marks)
- (iii) Calculate the steady state error if step input is applied. (5 marks)
- (iv) Find the value of K to give the steady state error of 0.2. (3 marks)
- (v) Find the steady state error for a parabolic input. (1 marks)

**Q4** (a) Figure Q4(a)(i) shows a position control system of a painting robot. The pole-zero plot of the robot dynamics is shown in Figure Q4(a)(ii). Find the value of the gain  $K$  of the controller using Routh Hurwitz stability criterion in order to obtain a stable system. (13 marks)

(b) Draw a Bode plot for a closed loop control system with unity feedback where;

$$G(s) = \frac{200}{(s + 2)(s + 4)(s + 5)}$$

(12 marks)

- Q5** (a) List at least one (1) function of Routh Hurwitz stability criterion in sketching root locus. (2 marks)

- (b) The characteristic equation for the unity feedback system with negative feedback is:

$$1 + KG(S)H(S) = 1 + \frac{K(s+3)}{(s+6)(s^2+4s+5)}$$

By using root locus techniques,

- (i) Construct its root locus. (12.5 marks)
- (ii) From the root locus calculate the value of  $K$  so that the damping ratio is  $\zeta = 0.422$ . (4.5 marks)
- (iii) Determine all the closed loop poles for the value of  $K$  obtained in Q5 b(ii). (6 marks)

- Q6** A positioning control system of an automatic drill with unity feedback has a plant (process) with the transfer function of:

$$G(s) = \frac{100}{s^3 + 13s^2 + 46s + 48}$$

and a controller with the gain of  $K$ . The system is operated at the damping ratio of 0.5.

- (a) A compensator cascading with the process will be added to reduce the steady state error by 50% while the damping ratio is maintained. What kind of compensator is suitable for this purpose? (3 marks)
- (b) Design the compensator. Choose the zero of the compensator equals to 0.1. (12 marks)
- (c) The compensator will be realized using an RC circuit and an amplifier. Calculate the value of each component in circuit of the compensator. Take  $C = 1\mu\text{F}$ . (10 marks)

FINAL EXAMINATION

SEMESTER/SESSION: SEM II/2010/11

PROGRAMME : 3BEE

COURSE : CONTROL SYSTEM

COURSE CODE: BEX 31603/ BEE 3143

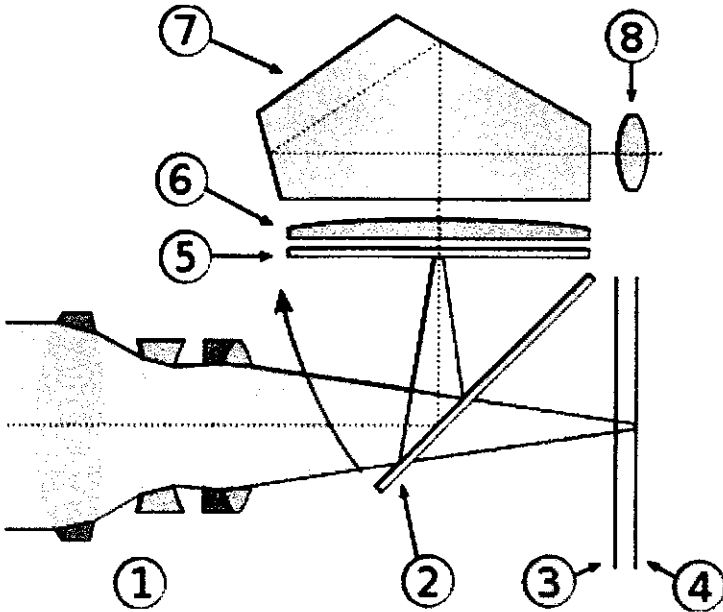

Legend:

1. 4-element lens
2. Reflex mirror
3. Focal-plane shutter
4. Image sensor
5. Matte focusing screen
6. Condenser lens
7. Pentaprism
8. Eyepiece

Figure Q1(b)

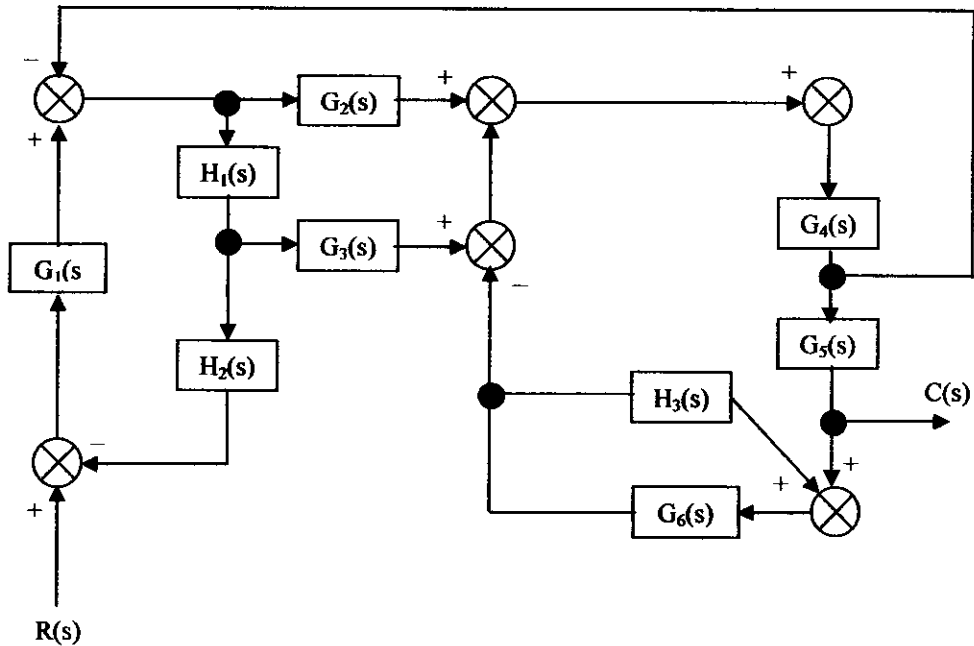

Figure Q2(a)

FINAL EXAMINATION

SEMESTER/SESSION: SEM II/2010/11

PROGRAMME : 3BEE

COURSE : CONTROL SYSTEM

COURSE CODE: BEX 31603/ BEE 3143

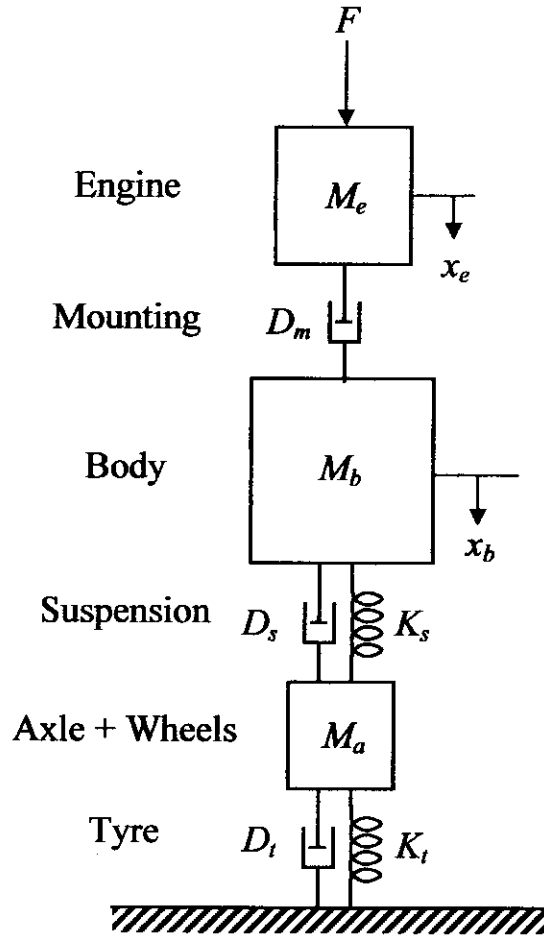

**Figure Q2(b)**

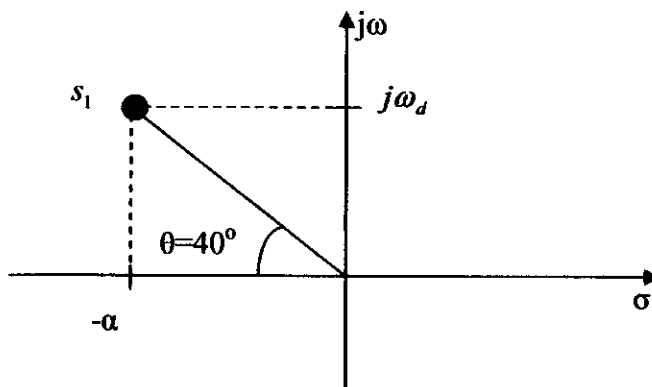

**Figure Q3(a)**

FINAL EXAMINATION

SEMESTER/SESSION: SEM II/2010/11

PROGRAMME : 3BEE

COURSE : CONTROL SYSTEM

COURSE CODE: BEX 31603/ BEE 3143

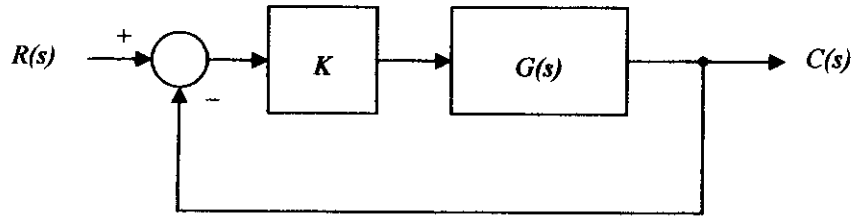

**Figure Q3(b)**

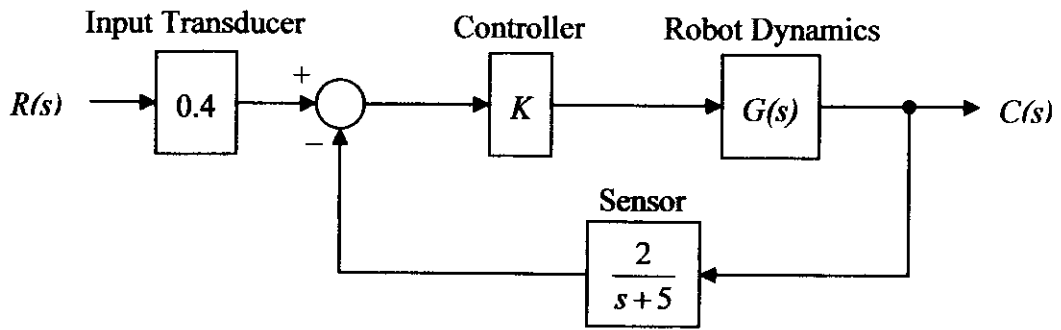

**Figure Q4(a)(i)**

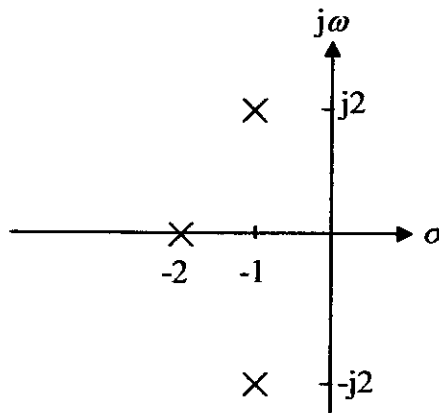

**Figure Q4(a)(ii)**