



# **UNIVERSITI TUN HUSSEIN ONN MALAYSIA**

## **FINAL EXAMINATION SEMESTER I SESSION 2010/11**

**COURSE NAME** : NEURAL NETWORK AND FUZZY LOGIC

**COURSE CODE** : BEM 4233

**PROGRAMME** : 4BEM

**EXAMINATION DATE** : NOVEMBER/DECEMBER 2010

**DURATION** : 2 ½ HOURS

**INSTRUCTION** : ANSWER FOUR (4) QUESTIONS ONLY

**THIS PAPER CONSISTS OF SEVEN (7) PAGES**

- Q1**
- (a) Create equation of equality, union, intersection and compliment for fuzzy set A and B with universe of discourse U. (7 marks)
  - (b) Describe the step of Mamdani Fuzzy Inference. (8 marks)
  - (c) Describe the two senses of the term Fuzzy Logic. (5 marks)
  - (d) Describe the brief history of Fuzzy logic system. (5 marks)
- Q2** A fuzzy control system has table rules as shown in Table Q2 and membership as triangular function.
- (a) Develop the active rules related with error is 2.5 and differential error is -1.25, if Universe discourse for each variable is  
 Error: NB [-6,-4,-2], N [-4,-3,-2], NS [-3,-2,-1], Z [-2,0,2], PS [1,2,3],  
 P [2,3,4], PB [2,4,6]  
 Differential error: NB [-6,-5,-4], N [-5,-3,-1], NS [-2,-1,0], Z [-1,0,1],  
 PS [0,1,2], P [1,3,5], PB [4,5,6]  
 Output: NB [-8,-6,-4], N [-6,-4,-2], NS [-4,-2,0], Z [-2,0,2], PS [0,2,4],  
 P [2,4,6], PB [4,6,8] (5 marks)
  - (b) Calculate the inference process from Q2(a) (17 marks)
  - (c) Calculate output crisp using COG method of Defuzzification (3 marks)
- Q3**
- (a) Explain process of developing a fuzzy expert system. (5 marks)
  - (b) Fuzzy control system is used to control the room temperature as shown in Figure Q3(b). Fuzzy controller has two inputs; they are the room temperature and the room humidity. The output is fan-speed. Temperature has membership function as cold, cool, warm, and hot. Humidity has low, medium, and high as membership functions. Fan-speed as output variable has membership function as zero, low, medium, and high. The controller has a function to maintain the room temperature to be warm. Decreasing humidity will increase temperature. Increasing fan-speed can reduce the air humidity.

- (i) Construct the related rule tabular for this fuzzy controller application. (14 marks)

- (ii) Design all possible rules for fuzzy controller application. (6 marks)

- Q4** (a) The output equation for single layer three inputs, one bias and one output artificial neural networks is given below:

$$a = x_1w_1 + x_2w_2 + x_3w_3 + b$$

Calculate the first epoch (means all the patterns are passed through once) plus the first iteration of the second epoch what happens to the weights when there be trained by the Hebbian algorithm, and fill in your answers into Table 3. (Learning rate,  $\alpha=0.4$ ).

(20 marks)

- (b) Four sample consists of  $\{X_1 = 1, X_2 = 1, t=1; X_1 = 0, X_2 = 1, t = 1; X_1=0, X_2= 0.5, t = 0; X_1 = -1, X_2 = 1, t = 0\}$  need to be train. Plot the given input  $X_1$  versus  $X_2$ . Analyze either it is possible to train the new sample using Perceptron algorithm.

(5 marks)

- Q5** A multilayer perceptron (MLP) can be designed with one hidden layers. One MLP model is given in Figure 5.

Logistic activation function:  $f(x) = \frac{1}{1 + e^{-x}}$

The weights of the interconnections have been initialized as shown. If all the neurons are logistic activation function except for input neurons i which are linear functions, calculate:

- (a) Calculate the output value ( $O_k$ ) of the MLP. (8 marks)

- (b) Calculate the change in weights of  $W_1, W_2, W_3, W_4, W_5, W_6, W_7, W_8, W_9$  and  $W_{10}$  for first iteration if target is one and learning rate,  $\eta=0.3$ .

(17 marks)

Note: you do not need to derive the Back Propagation (BP) algorithm and the error signals are given below:

Error signal between output and hidden layer:

$$\delta_k = (t_k - o_k) o_k (1 - o_k)$$

Error signal for all other layers:

$$\delta_i = o_i (1 - o_i) \sum_k \delta_k w_{ki}$$

**Q6** Consider the neural network model with two layers of hidden neurons as shown in Figure 6(a) has the following assumptions:

- Linear input and output neurons
- The activation functions for the hidden layer neurons are the logistic activation function:

$$f(x) = \frac{1}{1 + e^{-x}}$$

- Use symbols for neurons inputs and outputs as “net” and “O”.
- All neurons are fully connected from the lower layers to the upper layers and for hidden neurons there are bias inputs but there is no bias for the output neurons.

(a) Create the general equations for the forward propagation phase of this neural network based on the symbols as given.

(5 marks)

(b) Develop the equation for the adaptation of the weights between 1<sup>st</sup> hidden layers and the input layer if  $\Delta W_{jzi} = \alpha - \frac{\partial E}{\partial w_{jzi}}$ . Assume error,

$$E = \frac{1}{2} (t_k - O_k)^2$$

$$\text{Hint: } \frac{\partial f(x)}{\partial x} = \frac{1}{1 + e^{-x}} = f(x)(1 - f(x))$$

(15 marks)

(c) Assuming the same neural network model is configured as shown in Figure 6(b) with the values of the input, weights and biases as given in the figure, calculate the next weight for  $w_{jzi}$  when the target,  $t_k=1$  and learning rate,  $\eta=0.1$ .

(5 marks)

FINAL EXAMINATION

SEMESTER/SESSION : I / 2010/11  
 COURSE NAME : NEURAL NETWORK AND FUZZY LOGIC

PROGRAMME : 4 BEM  
 COURSE CODE : BEM 4233

**Tabel Q2: Rule tabulation**

u		e						
		NB	N	NS	Z	PS	P	PB
de	NB	NB	NB	NB	N	Z	P	PB
	N	NB	NB	NB	N	PS	P	PB
	NS	NB	NB	N	NS	PS	P	PB
	Z	NB	N	NS	Z	PS	P	PB
	PS	NB	N	NS	PS	P	PB	PB
	P	NB	N	NS	P	PB	PB	PB
	PB	NB	N	Z	P	PB	PB	PB

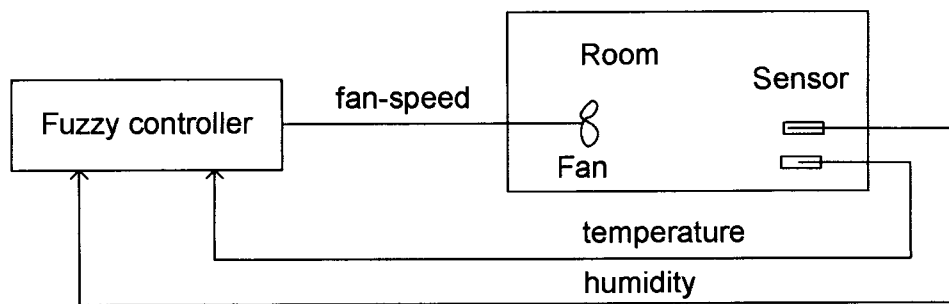

**Figure Q3(b)**

**Tabel Q3**

Iter	X <sub>1</sub>	X <sub>2</sub>	X <sub>3</sub>	T	Y	W <sub>1</sub>	W <sub>2</sub>	W <sub>3</sub>	b
0						0	0	0	1
1	1	1	1						
2	1	0	1						
3	0	1	1						
4	0	0	1						

FINAL EXAMINATION

SEMESTER/SESSION : I / 2010/11  
 COURSE NAME : NEURAL NETWORK AND FUZZY LOGIC

PROGRAMME : 4 BEM  
 COURSE CODE : BEM 4233

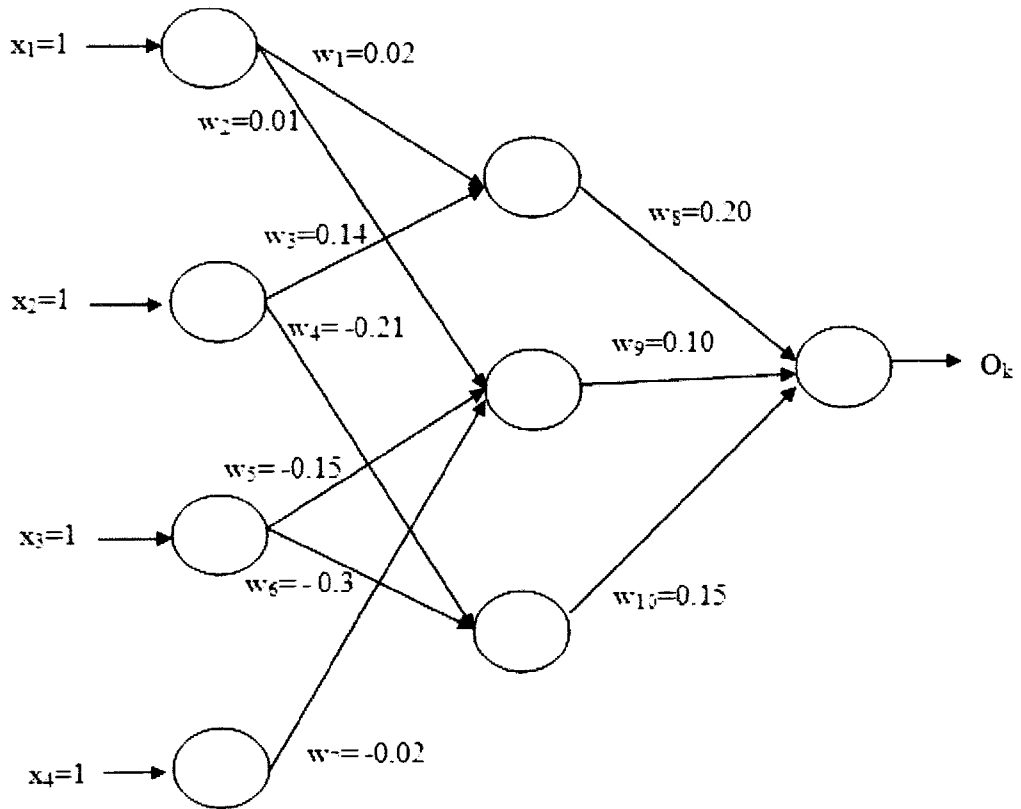
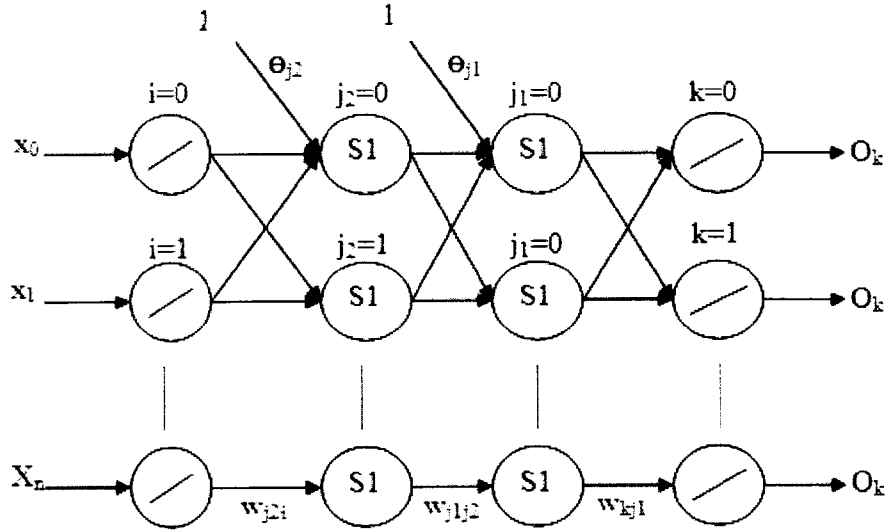

**Figure Q5**

FINAL EXAMINATION

SEMESTER/SESSION : I / 2010/11  
 COURSE NAME : NEURAL NETWORK AND FUZZY LOGIC

PROGRAMME : 4 BEM  
 COURSE CODE : BEM 4233



**Figure Q6 (a)**

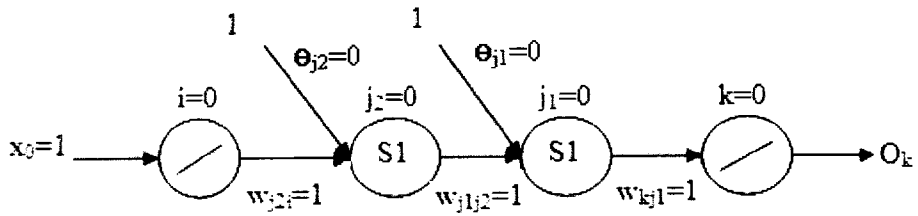

**Figure Q6 (b)**