



UNIVERSITI TUN HUSSEIN ONN MALAYSIA

FINAL EXAMINATION SEMESTER 2 SESSION 2012/2013

COURSE NAME : MECHANICS OF MACHINE

COURSE CODE : BDA 2033/20303

PROGRAMME : BACHELOR IN MECHANICAL
ENGINEERING WITH HONOURS

DATE : JUNE 2013

DURATION : 3 HOURS

INSTRUCTIONS : ANSWER ONLY **FOUR (4)** OUT OF FIVE
(5) QUESTIONS

THIS PAPER CONSIST OF EIGHT (8) PAGES

- Q1 (a)** A motor delivers 375 kW to the steel shaft AB as shown in **FIGURE Q1(a)**. The angular velocity of shaft AB, ω_{ab} is 100 rpm and angular velocity of the output shaft is 125 rpm. If the gear efficiency of the gear train is $\eta = 0.98$, calculate :
- (i) torque produced by the motor, τ_m and (4 marks)
- (ii) power at the output shaft, P and (2 Marks)
- (iii) torque at the output shaft, τ_o (4 Marks)
- (b)** A V-belt with groove angle 60° is use to transmit power between two pulleys at 1.5 m apart. The driver pulley of radius 50 mm runs at 1200 rpm, the follower pulley radius is 250 mm as shown in **FIGURE Q1(b)**.
- (i) Given the belt has a mass, m of 0.4 kg/m, the maximum tension, T_{max} is 750 N; coefficient of friction $\mu = 0.4$, find the maximum tension difference of the belt. (8 Marks)
- (ii) Given the belt cross section area, A is 320 mm^2 , and Young's Modulus, E for the material is 300 MN/m^2 , find the speed of the driven pulley and the power transmitted to it. (7 Marks)
- Q2** A four crank engine has two outer cranks set at 150° to each other and their reciprocating masses are each 500 kg. The distance between the planes of rotation of adjacent cranks are 400 mm, 800 mm and 600 mm as shown in **FIGURE Q2**. The radius for each crank is both 250 mm for outer cranks and 300 mm for inner cranks while the length of connecting rod is 1.2 m for outer cranks and 0.8 m for inner cranks.

- (i) Find the reciprocating masses and the relative angular position for each inner cranks if the engine is primary balance.

(15 marks)

- (ii) Find the maximum secondary unbalanced force if the engine rotates at 240 rpm

(10 marks)

- Q3** (a) **FIGURE Q3(a)** show a body has been pulled by a force P up a steady and inclined plane at 15° to the horizontal while **FIGURE Q3(b)** show the body been push down. An effort of 300 N is required to move the body up while 40 N is required to push the body down.

- (i) Calculate the weight of the body, w

(8 marks)

- (ii) Calculate the coefficient of friction, μ

(2 marks)

- (b) A dry plate clutch system is required to transmits 18 kW at 6000 rpm. The axial pressure, P is limited to 2 kN/m^2 . The outer diameter of the clutch is 400 mm while inner diameter is 200 mm and the coefficient of friction is 0.35. Use uniform pressure assumption.

- (i) Determine the minimum number of contact surface or pairs, n required for the system.

(12 marks)

- (ii) Based on your answer in Question 3(b)(i), find the exact axial force, W required for the system.

(3 marks)

- Q4** (a) Explained briefly about mechanism. With the help of diagram, list types of inversion in slider crank mechanism. (5 marks)
- (b) **FIGURE Q4** shows a space diagram of mechanism in a steam engine. With dimensions of the links are $AB = 12$ cm, $BC = 48$ cm, $CD = 18$ cm, $DE = 36$ cm, $EF = 12$ cm and $FP = 36$ cm,
- (i) Find the velocities, v of points C, D, E, F, and P. (15 marks)
- (ii) Find the torque produced at A if force 500 N is applied at slider P and system efficiency is 100%. (5 marks)
- Q5** (a) **FIGURE Q5(a)** shows a body ABOD with a 10 kg mass and radius of gyration, r_g of 50 mm to the centre of gravity at point O. The body is controlled by a spring and damper which are located at a distance of l , 40 mm from point O. Stiffness of spring at A is $K_1 = 2$ kN/m and at D is $K_2 = 1$ kN/m. Mass of M is 8 kg is attached to the body at D. Calculate
- (i) Distance h so that the system will oscillate at natural frequency of $\omega_n = 30$ rad/s. (10 marks)
- (iii) Damping coefficient at C if the amplitude of vibration reduces to $1/3$, after three complete oscillations. Ignore the pendulum effect of mass M . (5 marks)
- (b) A uniform thin rod AB as shown in **FIGURE Q5 (b)**, has a mass of 1 kg and carries with it concentrated mass of 2.5 kg at B. The rod is hinged at A and is maintained in the horizontal position by a spring of stiffness 1.8 kN/m at C. Neglecting the effect of the mass of the spring, find the natural frequency, ω of the system. (10marks)

- END OF QUESTION -

FINAL EXAMINATION

SEMESTER/SESSION : 2/2012/2013

PROGRAMME : 2 BDD

COURSE : MECHANICS OF MACHINE

COURSE CODE : BDA 20303

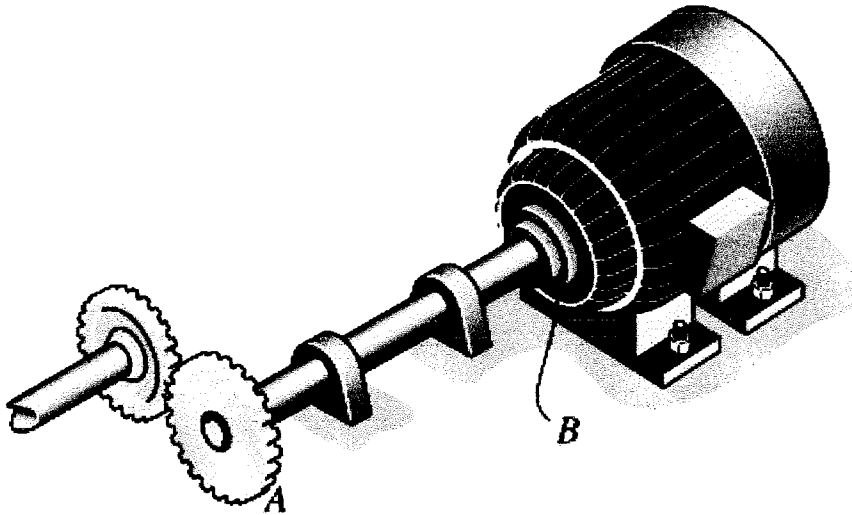

FIGURE Q1(a)

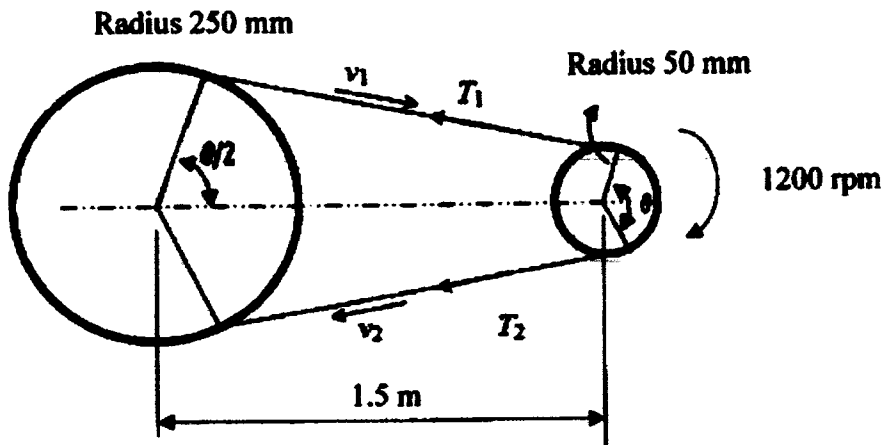

FIGURE Q1(b)

FINAL EXAMINATION

SEMESTER/SESSION : 2/2012/2013

PROGRAMME : 2 BDD

COURSE : MECHANICS OF MACHINE

COURSE CODE : BDA 20303

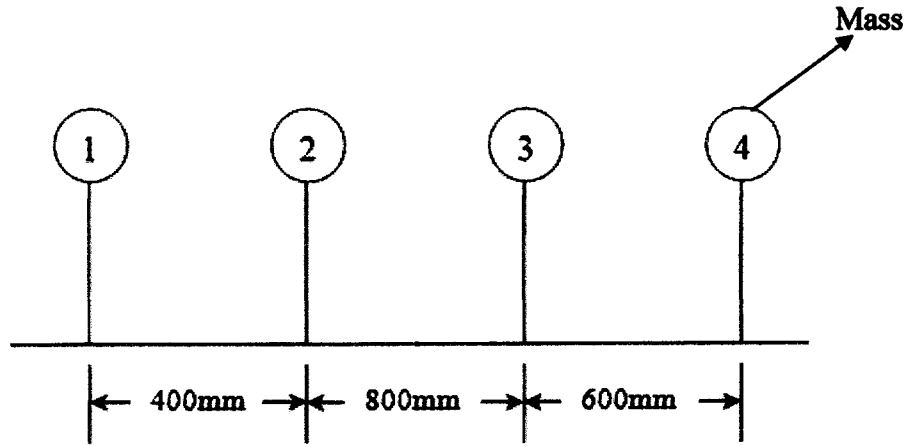

FIGURE 02

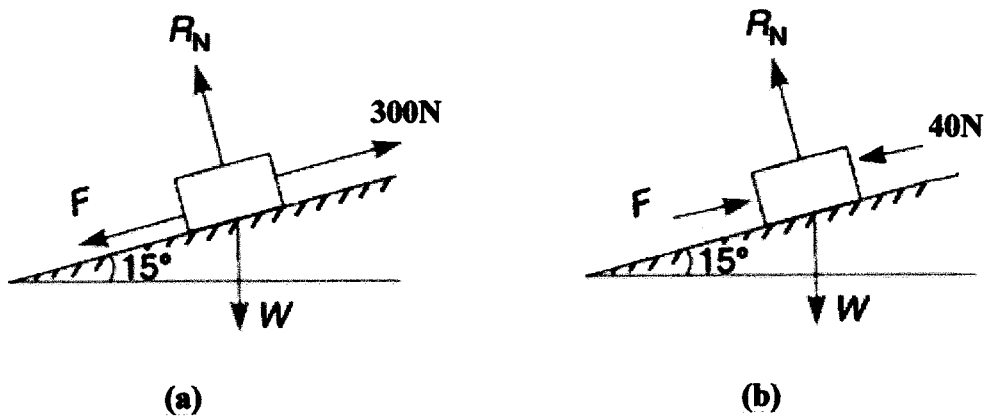

FIGURE 03

FINAL EXAMINATION

SEMESTER/SESSION : 2/2012/2013

PROGRAMME : 2 BDD

COURSE : MECHANICS OF MACHINE

COURSE CODE : BDA 20303

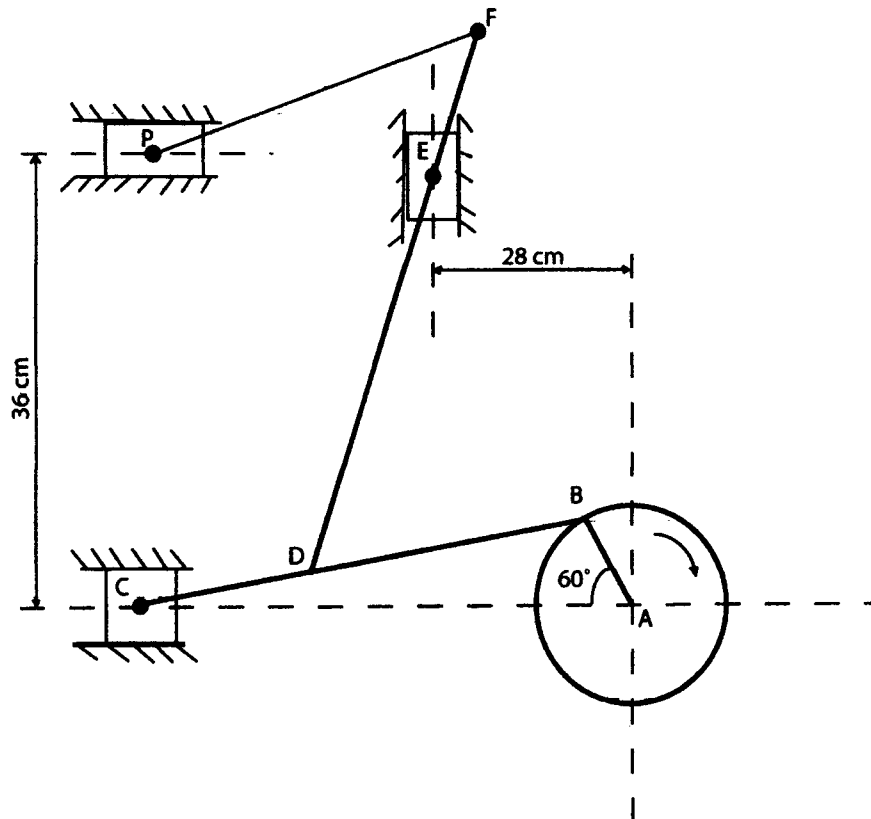

FIGURE 04

FINAL EXAMINATION

SEMESTER/SESSION : 1/2012/2013

PROGRAMME : 2 BDD

COURSE : MECHANICS OF MACHINE

COURSE CODE : BDA 20303

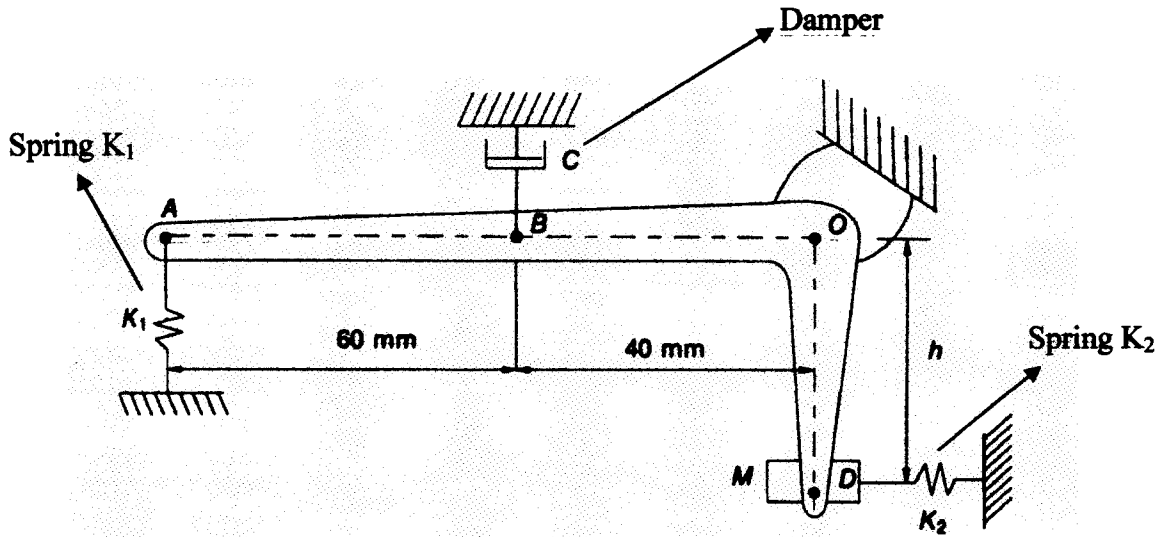

FIGURE Q5(a)

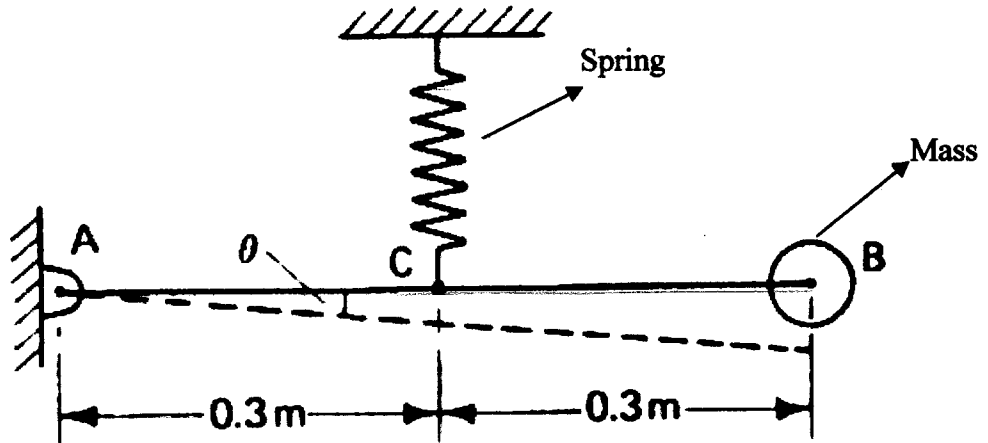

FIGURE Q5(b)