



**UNIVERSITI TUN HUSSEIN ONN MALAYSIA**

**FINAL EXAMINATION  
SEMESTER I  
SESSION 2012/2013**

**COURSE NAME** : STATIC AND DYNAMIC  
**COURSE CODE** : BFC 1022/ BFC10102  
**PROGRAMME** : 1 BFF  
**EXAMINATION DATE** : DECEMBER 2012/JANUARY 2013  
**DURATION** : 2 HOURS AND 30 MINUTES  
**INSTRUCTION** : ANSWER **THREE (3)** QUESTIONS  
IN PART A AND **ONE (1)** QUESTION  
IN PART B

THIS QUESTION PAPER CONSISTS OF **FIFTEEN (15)** PAGES

**PART A: ANSWER THREE (3) QUESTIONS ONLY**

- Q1** (a) All physical quantities in engineering mechanics are measured using either scalar or vector. Briefly explain the definition of scalar and vector. (5 marks)
- (b) Based on **Figure Q1 (a)**, determine the magnitude of the resultant force and its direction measured clockwise from the positive  $x$  axis. (10 marks)
- (c) Based on **Figure Q1 (b)**, determine the stretch in each spring for equilibrium of 2 kg block. The springs are shown in the equilibrium position. Given  $F_{\text{spring}} = k s$ ; (where  $s$  = stretch in the spring). (10 marks)
- Q2** (a) Define couple moment. (5 marks)
- (b) Replaced force system in **Figure Q2 (a)** with a resultant force and couple moment system at point  $O$ . (10 marks)
- (c) Based on **Figure Q2 (b)**, determine the force  $P$  needed to support the 20 kg mass. Determine the reactions at the supporting hooks A, B, and C. (10 marks)

- Q3** (a) Much time and energy has been spent in reducing the unwanted friction in machines and engines. The understanding and use of friction are important in our daily activities. Give the example of applications of friction in our daily activities.  
(5 marks)
- (b) Determine the vertical force  $P$  needed to rotate the 200 N spool in **Figure Q3 (a)**. The coefficient of static friction at all contacting surfaces is  $\mu_s = 0.4$ .  
(10 marks)
- (c) The platform truck supports the three loadings as shown in **Figure Q3 (b)**. Determine the normal reactions on each of its three wheels.  
(10 marks)
- Q4** (a) With the aid of diagram, compare the differences between three main centroids of gravity; line, area and volume.  
(5 marks)
- (b) Prove that the location of centroid for the composite structure shown in **Figure Q4** is  $\bar{x}, \bar{y} = (1, 0)$ .  
(10 marks)
- (c) Following the same structure in **Figure Q4**, forecast the value of moment of inertia about the  $x$  and  $y$  axis of the shaded area.  
(10 marks)

**PART B: ANSWER ONE (1) QUESTION ONLY**

- Q5** (a) Kinematics is an analysis of motion without concern for the forces causing the motion; which involving the quantity such as displacement, velocity, acceleration, and time. There are three types of motion in kinematics which are rectilinear motion, circular motion and general plane motion. Briefly explain **two (2)** of them.

(5 marks)

- (b) A bicyclist starts from rest and after travelling along a straight path a distance of 20 m reaches a speed of 30 km/h.

- (i) Determine his acceleration if it is constant.  
(ii) Also, how long does it take to reach the speed of 30 km/h?

(10 marks)

- (c) Travelling with an initial speed of 70 km/h, a car accelerates at  $6000 \text{ km/h}^2$  along a straight road.

- (i) How long will it take to reach a speed of 120 km/h?  
(ii) Also, through what distance does the car travel during this time?

(10 marks)

**Q6** (a) Briefly explain;

- (i) Hooke's Law,
- (ii) Energy Conservation Principle

(5 marks)

(b) A block with a mass of 8 kg is moving with a velocity of 7 m/s and collides with another block with a mass of 6 kg moving with a velocity of 5 m/s. Determine the velocity of block after the collision if both special moving in;

- (i) The same direction,
- (ii) The different direction. Given  $e = 0.5$ .

(16 marks)

(c) A force is applied to compress a spring to the wall. If the initial length of the spring is 25 cm and the last length is 10cm while the last force applied to the spring is 15N. Calculate;

- (i) The work done,
- (ii) The kinetic elastic energy exerts by the spring.

(14 marks)

**BAHAGIAN A: JAWAB TIGA (3) SOALAN SAHAJA**

- S1** (a) Kuantiti fizikal di dalam mekanik kejuruteraan diukur samada menggunakan skalar atau vektor . Terangkan dengan ringkas maksud skalar dan vektor.  
(5 markah)
- (b) Berdasarkan **Rajah Q1 (a)**, tentukan magnitud bagi daya paduan dan arah berdasarkan arah jam dari paksi  $x$  positif.  
(10 markah)
- (c) Berdasarkan **Rajah Q1 (b)**, tentukan regangan bagi setiap spring untuk keseimbangan bagi 2 kg bongkah. Spring berada di dalam keadaan keseimbangan. Diberi  $F_{\text{spring}} = ks$ ; (di mana  $s$  = regangan pada spring).  
(10 markah)
- S2** (a) Definisikan momen ganding.  
(5 markah)
- (b) Gantikan sistem daya dalam **Rajah Q2 (a)** kepada sistem daya paduan dan momen ganding pada titik O.  
(10 markah)
- (c) Berdasarkan **Rajah Q2 (b)**, tentukan daya P yang diperlukan untuk menyokong berat 20 kg. Tentukan tindakbalas yang menyokong cangkuk A, B dan C.  
(10 markah)

- S3 (a) Masa dan tenaga banyak digunakan untuk menghasilkan geseran yang tidak diperlukan pada mesin dan enjin. Kefahaman dan kegunaan geseran amat penting dalam aktiviti seharian. Berikan contoh aplikasi geseran dalam aktiviti harian kita.

(5 markah)

- (b) Tentukan daya tegak  $P$  yang diperlukan untuk memutarakan 200 N *spool* dalam **Rajah Q3 (a)**. Pekali geseran statik pada semua permukaan yang bersentuh ialah  $\mu_s = 0.4$ .

(10 markah)

- (c) Pelantar lori menyokong tiga beban seperti yang ditunjukkan dalam **Rajah Q3 (b)**. Tentukan tindakbalas normal bagi ketiga-tiga roda.

(10 markah)

- S4 (a) Dengan bantuan **Rajah Q4**, bandingkan perbezaan di antara sentroid graviti utama: garisan, luas dan isipadu.

(5 markah)

- (b) Buktikan bahawa lokasi sentroid bagi struktur jasad bergabung seperti yang ditunjukkan dalam **Rajah Q4** adalah  $\bar{x}, \bar{y} = (1, 0)$ .

(10 markah)

- (c) Berdasarkan struktur yang sama dalam **Rajah Q4**, ramalkan nilai momen sifat tekun terhadap paksi  $x$  dan  $y$  bagi kawasan berlerek.

(10 markah)

**BAHAGIAN B: JAWAB SATU (1) SOALAN SAHAJA**

- S5 (a) Kinematik adalah analisis pergerakan tanpa mengambilkira daya pergerakan di mana melibatkan kuantiti seperti sesaran/anjakan, halaju, pecutan dan masa. Terdapat tiga jenis pergerakan dalam kinematik iaitu gerakan melurus, gerakan mengeliling dan gerakan satah am. Terangkan secara ringkas dua daripada jenis tersebut.

(5 markah)

- (b) Seorang penunggang basikal memulakan kayuhan daripada keadaan pegun pada laluan yang lurus sejauh 20 m dengan kelajuan 30 km/j.

- (i) Tentukan pecutan penunggang tersebut jika ianya adalah malar.  
(ii) Berapa lamakah masa yang diambil untuk mencapai kelajuan 30 km/j?

(10 markah)

- (c) Pemanduan dengan kelajuan permulaan 70 km/j, sebuah kereta memecut sebanyak  $6000\text{km/j}^2$  sepanjang jalan yang lurus.

- (i) Berapa lamakah masa yang diambil untuk mencapai kelajuan 120 km/j?  
(ii) Sejauh manakah sesaran yang diperlukan oleh kereta tersebut sepanjang masa ini?

(10 markah)



**S6**

(a) Terangkan secara ringkas;

- i) Hukum Hooke,
- ii) Prinsip pengabadian tenaga.

(5 markah)

(b) Bongkah berjisim 8 kg bergerak dengan halaju 7 m/s dan berlanggar dengan bongkah yang lain yang mempunyai jisim 6 kg yang bergerak dengan halaju 5 m/s. Tentukan halaju bongkah selepas berlanggar jika kedua-dua bongkah bergerak dalam;

- i) Arah yang sama
- ii) Arah yang berbeza, diberi  $e = 0.5$

(16 markah)

(c) Daya dikenakan untuk memampatkan spring ke dinding. Jika panjang sebenar spring adalah 25 cm dan panjang selepas dimampatkan adalah 10 cm dan daya terakhir ialah 15 N. Kirakan;

- i) Kerja yang dihasilkan
- ii) Tenaga kekenyalan kinetik yang dihasilkan oleh spring

(4 markah)

**FINAL EXAMINATION**

SEMESTER / SESSION : SEM I / 2012/2013  
 COURSE : STATIC AND DYNAMIC

PROGRAMME : 1BFF  
 COURSE CODE : BFC 1022/10102

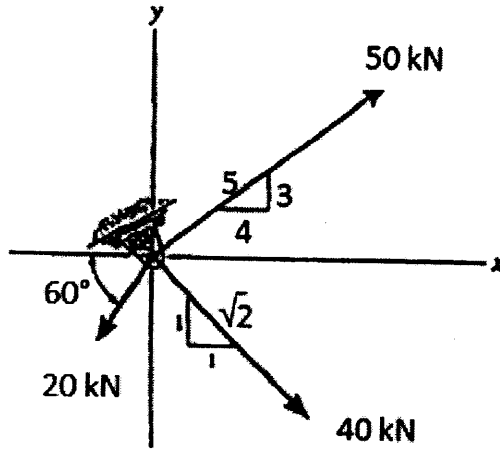

**FIGURE Q1(a)**

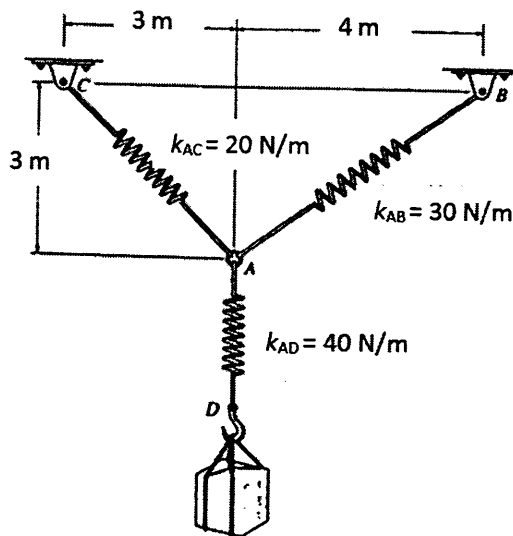
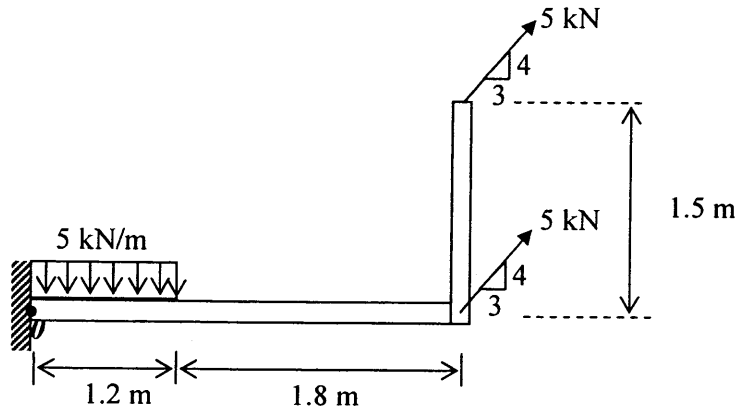

**FIGURE Q1(b)**

**FINAL EXAMINATION**

SEMESTER / SESSION : SEM I / 2012/2013  
 COURSE : STATIC AND DYNAMIC

PROGRAMME : 1 BFF  
 COURSE CODE : BFC 1022/10102



**FIGURE Q2(a)**

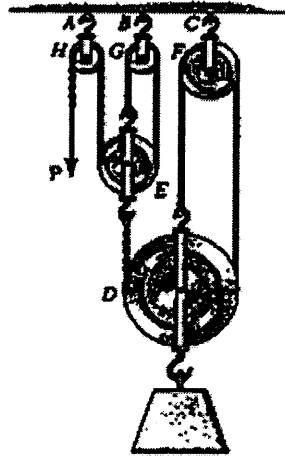
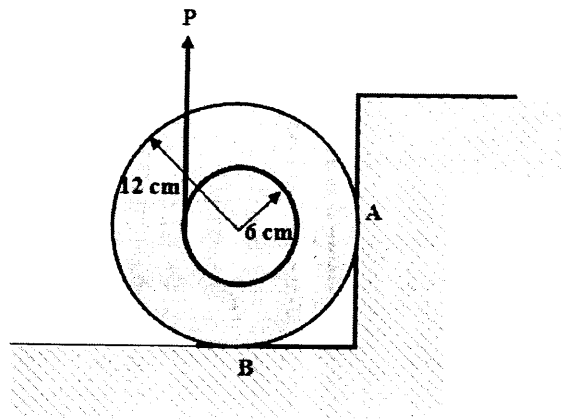

**FIGURE Q2(b)**

**FINAL EXAMINATION**

SEMESTER / SESSION : SEM I / 2012/2013  
 COURSE : STATIC AND DYNAMIC

PROGRAMME : 1 BFF  
 COURSE CODE : BFC 1022/10102



**FIGURE Q3(a)**

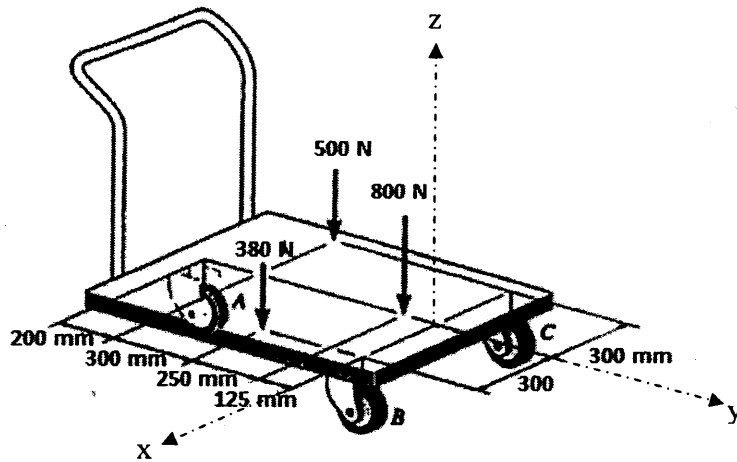
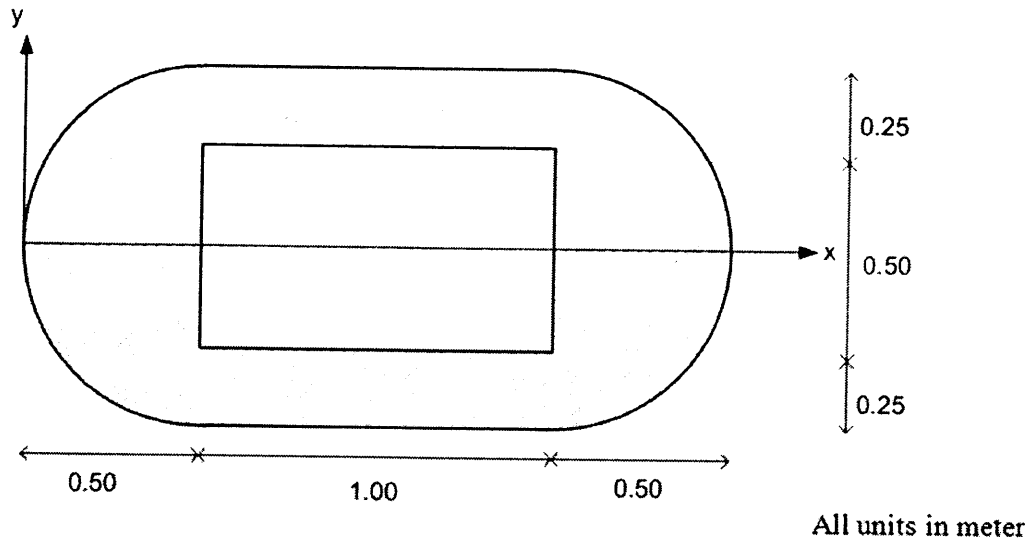

**FIGURE Q3(b)**

**FINAL EXAMINATION**

SEMESTER / SESSION : SEM I / 2012/2013  
COURSE : STATIC AND DYNAMIC

PROGRAMME : 1 BFF  
COURSE CODE : BFC 1022/10102



**FIGURE Q4**

**FINAL EXAMINATION**

SEMESTER / SESSION : SEM I / 2012/2013  
 COURSE : STATIC AND DYNAMIC

PROGRAMME : 1 BFF  
 COURSE CODE : BFC 1022/10102

**APPENDIX**

**Table 1 : Centroid**

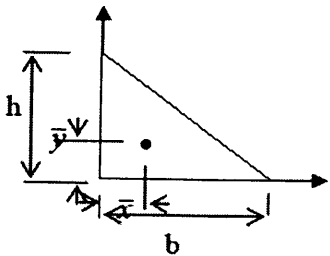
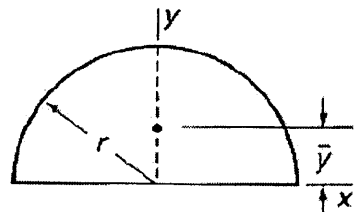
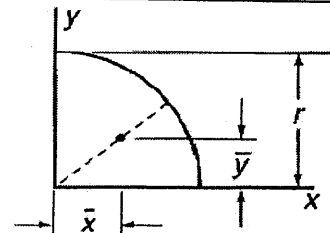
|                | SHAPE  | $\bar{x}$         | $\bar{y}$         | A                   |
|----------------|--|-------------------|-------------------|---------------------|
| Triangle       |   | $\frac{b}{3}$     | $\frac{h}{3}$     | $\frac{1}{2}bh$     |
| Semicircle     |   | 0                 | $\frac{4r}{3\pi}$ | $\frac{\pi r^2}{2}$ |
| Quarter circle |  | $\frac{4r}{3\pi}$ | $\frac{4r}{3\pi}$ | $\frac{\pi r^2}{4}$ |

**Table 2 : Moment of Inertia**

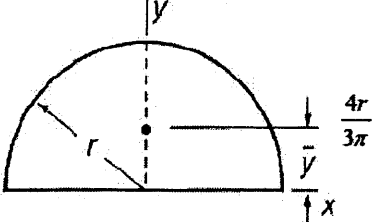
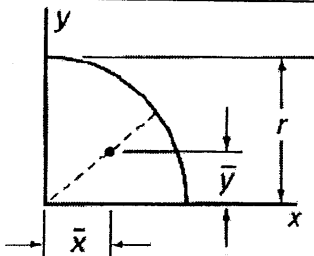
|                |   |  |
|----------------|---|--|
| Semicircle     |  | $I_x = I_y = \frac{1}{8}\pi r^4$ $J = \frac{1}{4}\pi r^4$  |
| Quarter circle |  | $I_x = I_y = \frac{1}{16}\pi r^4$ $J = \frac{1}{8}\pi r^4$ |

**FINAL EXAMINATION**

SEMESTER / SESSION : SEM I / 2012/2013  
 COURSE : STATIC AND DYNAMIC

PROGRAMME : 1 BFF  
 COURSE CODE : BFC 1022/10102

**LIST OF EQUATION**

$$s = v_0 t + \frac{1}{2} a t^2$$

$$v = v_0 + a t$$

$$v^2 = v_0^2 + 2 a s$$

Elastic Collision

$$m_1 u_1 + m_2 u_2 = m_1 v_1 + m_2 v_2$$

$$m_1 u_1 - m_2 u_2 = m_1 v_1 + m_2 v_2$$

$$m_1 u_1 + 0 = m_1 v_1 + m_2 v_2$$

Inelastic Collision

$$m_1 u_1 + m_2 u_2 = (m_1 + m_2) v_1$$

Coefficient of Elasticity

$$\frac{v_2 - v_1}{u_1 - u_2} = e \quad \dots\dots\dots 0 \leq e \leq 1$$

If  $e = 0$ , the material is not elastic

If  $e = 1$ , the material is fully elastic.

If  $e = 0$ , inelastic collision,  $v_1 = v_2 = v \rightarrow m_1 u_1 + m_2 u_2 = (m_1 + m_2) v$

If  $e = 1$ , elastic collision,  $v_2 - v_1 = u_1 - u_2$

Hooke's Law

$$U = \frac{1}{2} F x \quad @ \quad \frac{1}{2} F s$$

$$= \frac{1}{2} k x^2$$

$$= \frac{1}{2} k (\Delta x)^2$$

Energy, power, work

$$E = m g h$$

$$E = \frac{1}{2} m v^2$$

$$P = \frac{\text{Work}}{\text{time}} = \frac{W(J)}{T(s)}$$

$$\text{Work} = \frac{1}{2} F \cdot (\Delta x)^2$$