



**UNIVERSITI TUN HUSSEIN ONN MALAYSIA**

**FINAL EXAMINATION  
SEMESTER I  
SESSION 2010/2011**

COURSE	:	TECHNICAL COMMUNICATION 1
CODE	:	UMB 1112
PROGRAMME	:	1 DFA/DFT
DATE	:	NOVEMBER/DECEMBER 2010
DURATION	:	2 HOURS
INSTRUCTION	:	ANSWER ALL QUESTIONS IN THE SPACES PROVIDED

Name: \_\_\_\_\_

Matric No: \_\_\_\_\_

FACULTY OF SCIENCE, ARTS AND HERITAGE  
UNIVERSITI TUN HUSSEIN ONN MALAYSIA

Name of Candidate : \_\_\_\_\_

Identity Card No : \_\_\_\_\_

Matric No : \_\_\_\_\_

Subject Code : \_\_\_\_\_

Date/Time : \_\_\_\_\_

Name of Lecturer : \_\_\_\_\_

Name: \_\_\_\_\_

Matric No: \_\_\_\_\_

**Q1** Figure 1 below shows parts of an EPSON Stylus DX printer. Based on the notes given and the diagram, write a technical description of the printer. You should include technical definition, physical and functional aspects of the object in your description.

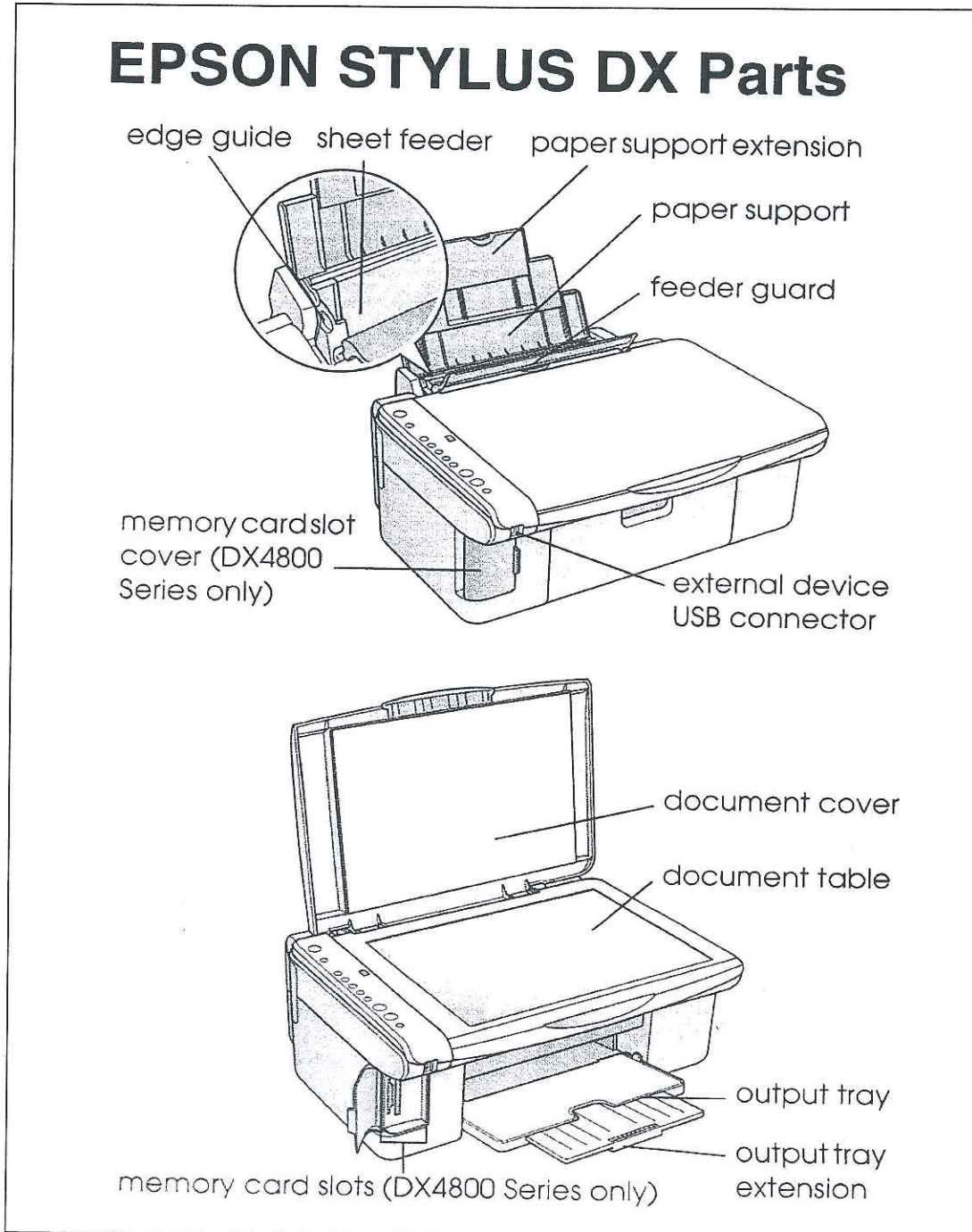

Figure 1: EPSON Stylus DX

(40 marks)





Name: \_\_\_\_\_

Matric No: \_\_\_\_\_

**Q2** Match the correct term and its purpose.

<b>Term</b>	<b>Purpose</b>
(i) Planning Proposal	(a) to inform supervisors if the work is on schedule.
(ii) Progress Report	(b) to inform the status or result of a project or research that is held outside of the workplace/field.
(iii) Field Trip Report	(c) to suggest a solution in order to improve a current situation / status.
(iv) Research Proposal	(d) to explain the suitability or a condition of specific items.
(v) Inspection Report	(e) to ask for a grant or fund from certain organization in order to carry out an experiment or study.

(5 marks)

**Q3** Give 4 examples of primary data sources:

- (a) \_\_\_\_\_
- (b) \_\_\_\_\_
- (c) \_\_\_\_\_
- (d) \_\_\_\_\_

(4 marks)

Name: \_\_\_\_\_

Matric No: \_\_\_\_\_

**Q4** Form suitable questions for the following answers.

(a) Question: \_\_\_\_\_

Answer: *I have been studying in UTHM for two semesters.*

(b) Question: \_\_\_\_\_

Answer: *The Physics experiment that I am working on is long and difficult.*

(c) Question: \_\_\_\_\_

Answer: *I strongly disagree the ban of Facebook application in the university campus.*

(d) Question: \_\_\_\_\_

Answer: *It is because students cannot manage their time effectively.*

(e) Question: \_\_\_\_\_

Answer: *I prefer face-to-face consultation with the lecturer to e-mail them.*

(10 marks)

**Q5** Planning or Project Proposal is a technical document that attempts to persuade readers to accept ideas, and to emphasise the benefits of the proposed programme. It also contains statements of objectives, as well as facts and figures that lead to clear statements of planning. Based on what you have learned in class, write the basic components of a proposal.

(a) \_\_\_\_\_

(b) \_\_\_\_\_

(c) \_\_\_\_\_

(d) \_\_\_\_\_

(e) \_\_\_\_\_

(f) \_\_\_\_\_

(6 marks)



Name: \_\_\_\_\_

Matric No: \_\_\_\_\_

**Q6** Change the following sentences into the passive voice

(a) The supervisor advised the technician to check all the laboratory equipment.

\_\_\_\_\_

(b) The tutor had returned the marked assignments to the students.

\_\_\_\_\_

(c) The librarian suggested the 'Guide to Composition' book to the new students for reference in writing.

\_\_\_\_\_

\_\_\_\_\_

(d) Majority of the class prefer face-to-face consultation with the lecturer.

\_\_\_\_\_

(e) All committee members in the University Students' Representative Council participated in the community service programme in Segamat.

\_\_\_\_\_

\_\_\_\_\_

(15 marks)





