



UNIVERSITI TUN HUSSEIN ONN MALAYSIA

**FINAL EXAMINATION
SEMESTER I
SESSION 2019/2020**

COURSE NAME : ELECTRICAL TECHNOLOGY
COURSE CODE : DAE 11003
PROGRAMME CODE : DAE
EXAMINATION DATE : DECEMBER 2019 / JANUARY 2020
DURATION : 3 HOURS
INSTRUCTION : ANSWER **FOUR (4)** QUESTIONS ONLY

TERBUKA

THIS QUESTION PAPER CONSISTS OF **EIGHT (8)** PAGES

- Q1**
- (a) Define Ohm's Law. (3 marks)
- (b) Explain what a 'valence electron' is. (2 marks)
- (c) Convert the following:
- (i) 0.000765 watt (W) to milliwatts (mW) (1.5 marks)
- (ii) 5864 μ W to watts (W) (1.5 marks)
- (d) Determine the resistance values for the following:
- (i) Gray, red, blue, silver (3 marks)
- (ii) White, violet, brown, gold (3 marks)
- (e) Referring to **Figure Q1 (e)**, show the placement of an ammeter and a voltmeter to measure the:
- (i) Total circuit current (2.5 Marks)
- (ii) The source voltage (2.5 Marks)
- (f) A certain power supply provides a continuous 4W to a load. It is operating at 85% efficiency. In a 20 hours period, calculate the total kilowatt-hours the power supply use. (6 Marks)
- Q2**
- (a) **Three (3)** batteries which are connected in series produce 10 mA in the circuit. Each of the battery voltage is 4 V. Determine the power of the circuit. (4 marks)
- (b) Determine the value of R_5 , if the total resistance in **Figure Q2 (b)** is 17.4 k Ω . (3 marks)
- (c) Determine the values of V_{R1} , R_2 and R_3 referring to **Figure Q2 (c)**. (6 marks)

TERBUKA

(d) Referring to **Figure Q2 (d)**, calculate:

- (i) Power at R_1 (2 marks)
- (ii) Voltage Supply, V_s (2 marks)
- (iii) Current flow at R_2 , I_2 (2 marks)
- (iv) Resistor Value of R_2 (2 marks)
- (v) Current flow at R_1 , I_1 (2 marks)
- (vi) Resistor Value of R_1 (2 marks)

Q3 (a) Referring to **Figure Q3 (a)**:

- (i) Calculate the total current from the power supply (I_T). (4 marks)
- (ii) Determine current through each resistor (I_2, I_3, I_4, I_5, I_6) (4 marks)
- (iii) Determine the voltage at node A with respect to ground. (2 marks)

(b) By referring to **Figure Q3 (b)**, determine the followings:

- (i) Magnetizing force, H . (4 marks)
- (ii) Magnetic flux, Φ . (7 marks)
- (iii) Magnetic flux density, B . (1 mark)

(c) By referring to **Figure Q3 (c)**, determine the following:

- (i) Flux density in the core. (2 marks)
- (ii) Show the north and south poles of the magnet. (1 mark)

Q4. (a) (i) Define frequency. (1 mark)
 (ii) Sketch a 3 Hz sine wave frequency. (2 marks)

(b) Convert the following angular values from radians to degrees:
 (i) $3\pi/5$ rad (2 marks)
 (ii) 1.8π rad (2 marks)

(c) Calculate the rms voltage across R_3 referring to **Figure Q4 (c)**. (9 marks)

(d) Perform the following operations:
 (i) $(3.8 \angle 75^\circ) + (1 + j1.8)$ (3 Marks)
 (ii) $(-45 - j23) - (36 + j12)$ (3 Marks)
 (iii) $\frac{28 \angle 30^\circ}{14 - j12}$ (3 Marks)

TERBUKA

- Q5** (a) Draw and label completely the basic circuit of the transformer. (2 marks)
- (b) An ideal transformer has 2000 turns in the primary coil and 100 turns in the secondary coil. The primary terminal of the transformer is connected to an AC supply of 2400 V, 50 Hz and the current flows in the primary circuit is 10.4 A. Determine the following:
- (i) The type of the transformer used. (1 marks)
 - (ii) The turn's ratio. (2 marks)
 - (iii) The voltage on the secondary. (2 marks)
 - (iv) The load current. (2 marks)
 - (v) The input power supplied to the primary. (2 marks)
 - (vi) The output power delivered to the load. (2 marks)
- (c) Name the following:
- (i) The stationary part of the machine. (1 mark)
 - (ii) The rotating part of the machine. (1 mark)
- (d) Draw and label completely the basic circuit of the separately excited of DC generator. (2 marks)
- (e) State the function of the commutator in the DC machines. (2 marks)
- (f) Give two (2) examples of applications for each of the following:
- (i) The series wound DC motors. (2 marks)
 - (ii) The shunt wound DC motors. (2 marks)
 - (iii) The compound wound DC motors. (2 marks)

TERBUKA

-END OF QUESTIONS -

FINAL EXAMINATION

SEMESTER / SESSION : SEM I / 2019/2020
COURSE NAME : ELECTRICAL TECHNOLOGY

PROGRAMME CODE : DAE
COURSE CODE : DAE 11003

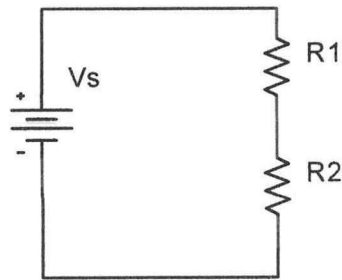

Figure Q1 (e)

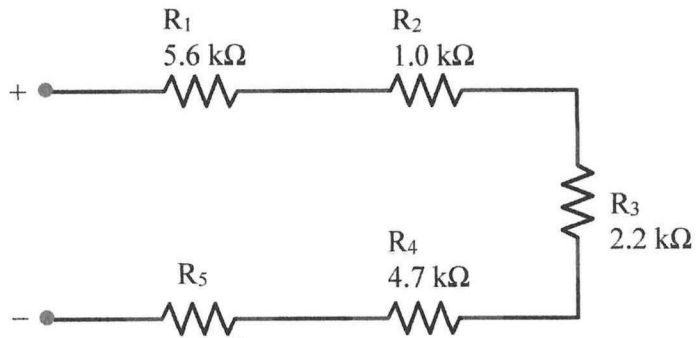

Figure Q2 (b)

TERBUKA

FINAL EXAMINATION

SEMESTER / SESSION : SEM 1 / 2019/2020
COURSE NAME : ELECTRICAL TECHNOLOGY

PROGRAMME CODE : DAE
COURSE CODE : DAE 11003

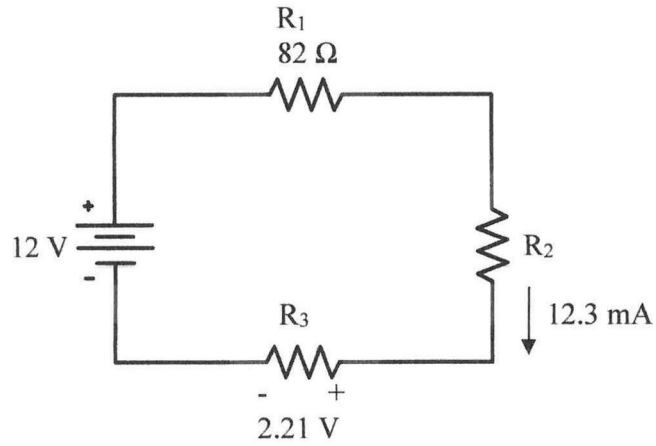

Figure Q2 (c)

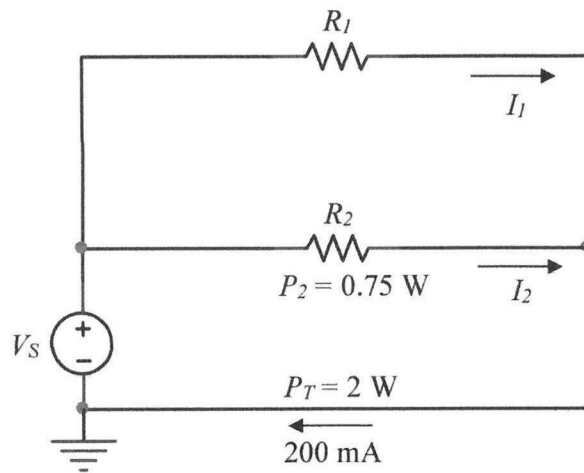

Figure Q2 (d)

TERBUKA

FINAL EXAMINATION

SEMESTER / SESSION : SEM 1 / 2019/2020
COURSE NAME : ELECTRICAL TECHNOLOGY

PROGRAMME CODE : DAE
COURSE CODE : DAE 11003

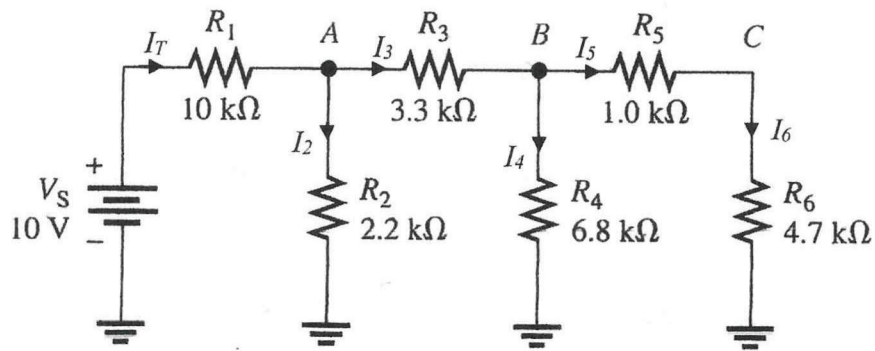

Figure Q3 (a)

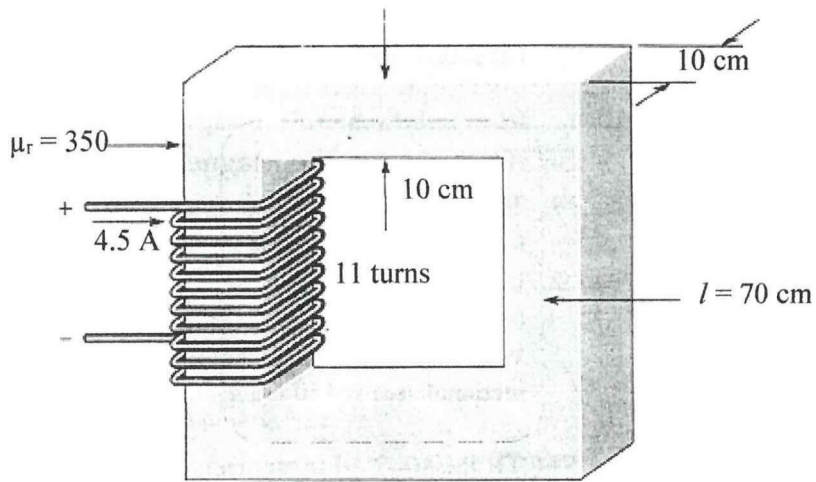

Figure Q3 (b)

TERBUKA

FINAL EXAMINATION

SEMESTER / SESSION : SEM 1 / 2019/2020
COURSE NAME : ELECTRICAL TECHNOLOGY

PROGRAMME CODE : DAE
COURSE CODE : DAE 11003

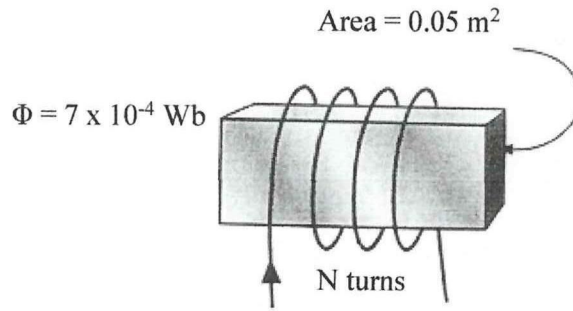

Figure Q3 (c)

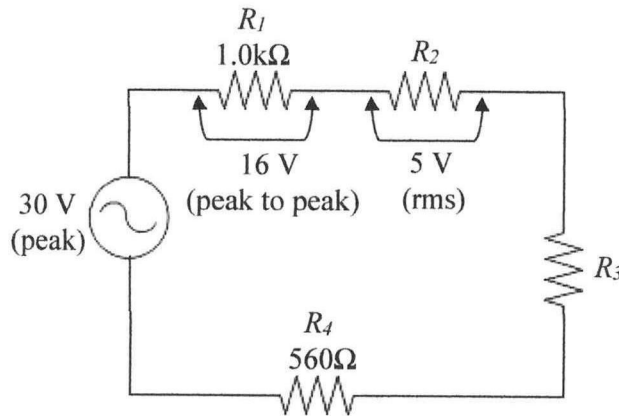

Figure Q4 (c)

TERBUKA