



**UNIVERSITI TUN HUSSEIN ONN MALAYSIA**

**FINAL EXAMINATION  
SEMESTER II  
SESSION 2023/2024**

- COURSE NAME : ENGINEERING TECHNOLOGY  
MATHEMATICS II
- COURSE CODE : BDX 10502
- PROGRAMME CODE : BDX
- EXAMINATION DATE : JULY 2024
- DURATION : 2 HOURS
- INSTRUCTIONS :
1. ANSWER **FOUR (4)** QUESTIONS FROM FIVE (5) QUESTIONS ONLY
  2. THIS FINAL EXAMINATION IS CONDUCTED VIA
    - Open book
    - Closed book
  3. STUDENTS ARE **PROHIBITED** TO CONSULT THEIR OWN MATERIAL OR ANY EXTERNAL RESOURCES DURING THE EXAMINATION

THIS QUESTION PAPER CONSISTS OF **FOUR (4)** PAGES

**TERBUKA**

**CONFIDENTIAL**

**Q1** (a) Solve equation  $2x + y = 8$  and  $x+2y = 1$  using Gauss Seidel Method. (15 marks)

(b) Examine the slope of the surface given by  $f(x, y) = -\frac{x^2}{2} - y^2 + \frac{25}{8}$  at the point  $(1/2, 1, 2)$  in the x-direction and y-direction. (10 marks)

**Q2** (a) Evaluate the Lagrange Interpolating Polynomial for data  $(5,12), (6,13), (7,14)$  and  $(8,15)$ . Hence, evaluate  $f(10)$ . (15 marks)

(b) Use cylindrical coordinates to calculate  $\iiint_G xy dV$ , if  $G$  is a cylinder  $x^2 + y^2 \ll 1$  and  $0 \ll z \ll 1$  (10 marks)

**Q3** (a) A periodic function  $f(x)$  is defined by

$$F(x) = x, \quad -1 < x < 1$$

and

$$f(x) = f(x+2)$$

i) Sketch the graph of the function over  $-3 < x < 3$  (6 marks)

ii) Examine the Fourier coefficients corresponding to the function. (10 marks)

iii) Solve the corresponding Fourier series. (9marks)

**Q4** (a) Identify nodal displacements, stresses in each materials and the reaction forces as shown in **APPENDIX A.1**. (15 marks)

(b) Given the function  $f(x) = \sin 2x + x^3 - 3$ . Solve the root of  $f(x)$  by using Newton-Raphson method. (10 marks)

**TERBUKA**

- Q5** (a) Solve the following differential equation

$$x \frac{\partial y}{\partial x} - 3 = 2 \left( y + \frac{\partial y}{\partial x} \right)$$

which satisfies the initial condition  $y = 0$  when  $x = 3$ .

(15 marks)

- (a) Solve the general solution of the following equation.

$$(x + y) \frac{\partial y}{\partial x} = y$$

(10 marks)

**- END OF QUESTIONS -**

**TERBUKA**

APPENDIX A

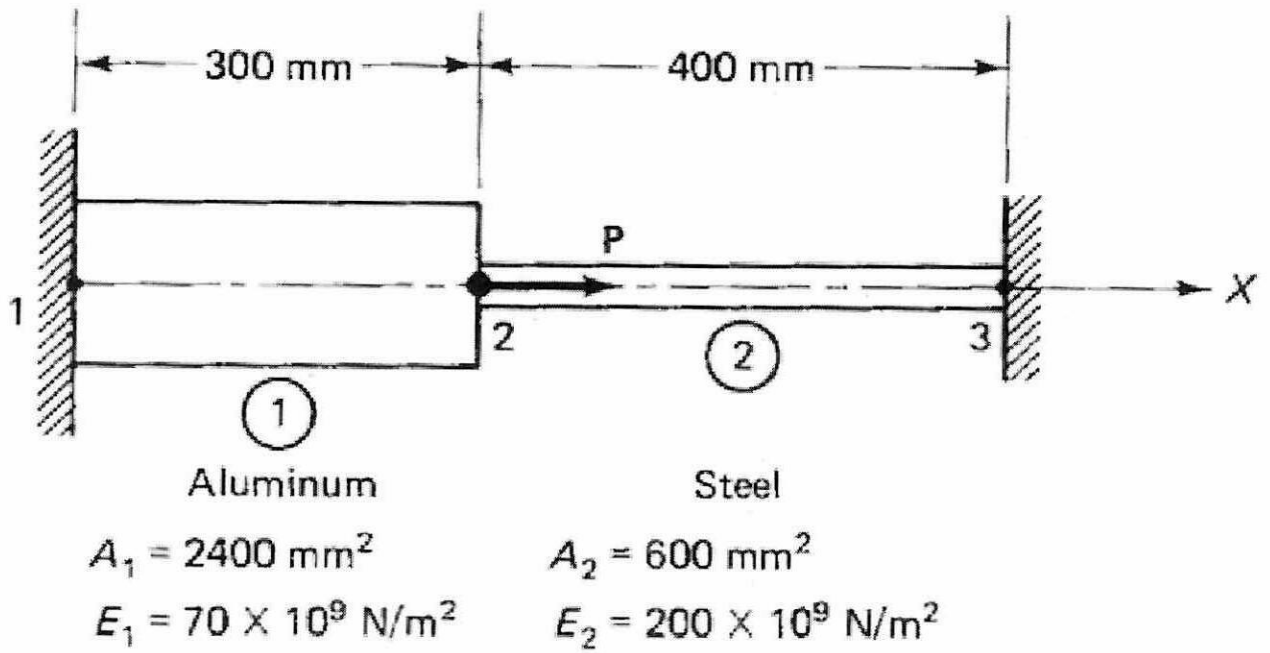

Figure APPENDIX A.1

TERBUKA