

CONFIDENTIAL



UNIVERSITI TUN HUSSEIN ONN MALAYSIA

**FINAL EXAMINATION
SEMESTER I
SESSION 2022/2023**

COURSE NAME : ROBOTIC SYSTEMS
COURSE CODE : BEJ 44203
PROGRAMME CODE : BEJ
EXAMINATION DATE : FEBRUARY 2023
DURATION : 3 HOURS
INSTRUCTION :
1. ANSWER ALL QUESTIONS
2. THIS FINAL EXAMINATION IS CONDUCTED VIA **CLOSED BOOK**
3. STUDENTS ARE **PROHIBITED** TO CONSULT THEIR OWN MATERIAL OR ANY EXTERNAL RESOURCES DURING THE EXAMINATION CONDUCTED VIA CLOSED BOOK

THIS QUESTION PAPER CONSISTS OF **FOUR (4)** PAGES

TERBUKA

CONFIDENTIAL

- Q1** (a) State **TWO (2)** factors that might affect the repeatability and accuracy of a manipulator. (2 marks)
- (b) The corresponding arm parameters and the forward kinematics matrix for a spherical arm with two rotary joints and prismatic joints as follows:

$$H_0^3 = \begin{bmatrix} -S_1 & C_1 C_2 & C_1 S_2 & d_3 C_1 S_2 + d_2 S_1 \\ C_1 & S_1 C_2 & S_1 S_2 & d_1 S_1 S_2 - d_2 C_1 \\ 0 & S_2 & -C_2 & d_1 - d_3 C_2 \\ 0 & 0 & 0 & 1 \end{bmatrix}$$

- (i) Derive the position vector of the tip of the arm. (2 marks)
- (ii) Obtain the solution of θ_1 and d_3 . (8 marks)
- (c) **Figure Q1(c)** shows a three-link planar arm with three joints. Derive the Jacobian for the three-link arm. The homogenous transformation matrices are given as follows:

$$H_0^1 = \begin{bmatrix} C\theta_1 & 0 & S_1 & 0 \\ S\theta_1 & 0 & -C_1 & 0 \\ 0 & 1 & 0 & \alpha_1 \\ 0 & 0 & 0 & 1 \end{bmatrix}$$

$$H_1^2 = \begin{bmatrix} -S\theta_1 & 0 & C\theta_2 & \alpha_2 C\theta_2 \\ C\theta_1 & 0 & S\theta_2 & \alpha_2 S\theta_2 \\ 0 & 1 & 0 & 0 \\ 0 & 0 & 0 & 1 \end{bmatrix}$$

$$H_0^3 = \begin{bmatrix} 1 & 0 & 0 & 0 \\ 0 & 1 & 0 & 0 \\ 0 & 0 & 1 & \alpha_3 + 3 \\ 0 & 0 & 0 & 1 \end{bmatrix}$$

(13 marks)

- Q2** (a) A single-link robot with a rotary joint is motionless at $\theta = -5^\circ$. It is desired to move the joint in a smooth manner to $\theta = 80^\circ$ in 4 seconds. The initial velocity and final velocity are zero. Design a cubic trajectory to accomplish this motion and bring the arm to the rest at the goal.

(13 marks)

- (b) Solve for the coefficients of two-segments of continuous velocity and acceleration spline with initial angle is $\theta_0 = 5^\circ$. The via point is $\theta_v = 15^\circ$, and the goal point is $\theta_g = 40^\circ$. The designated trajectory should have zero initial velocity and zero final velocity. Each segment lasts 1.0 seconds.

The first cubic ($0 \leq t \leq 1$) is

$$\theta(t) = a_{10} + a_{11}t + a_{12}t^2 + a_{13}t^3$$

and the second cubic ($1 \leq t \leq 2$) is

$$\theta(t) = a_{20} + a_{21}(t - 1) + a_{22}(t - 1)^2 + a_{23}(t - 1)^3$$

(12 marks)

- Q3** Consider the point masses at distal ends of link of the following two-link manipulator as shown in **Figure Q3**. The link lengths are described by l_1 and l_2 .

- (a) Find the Cartesian coordinates of the point masses m_1 and m_2 .

(5 marks)

- (b) Calculate the velocities of the point masses m_1 and m_2 .

(8 marks)

- (c) Evaluate the differential equation of T_{θ_1} for the first link of the manipulator.

(12 marks)

- Q4** (a) Identify the natural and artificial constraints for the task of closing a hinged door with manipulator. Make any reasonable assumptions needed and show your definition of $\{C\}$ in sketch.

(18 marks)

- (b) Discuss **ONE** example of the application of hybrid position/force controller in robot manipulator operation.

(7 marks)

-END OF QUESTIONS -

FINAL EXAMINATION

SEMESTER / SESSION: SEM I 2022/2023
COURSE NAME: ROBOTIC SYSTEMS

PROGRAMME CODE: BEJ
COURSE CODE: BEJ 44203

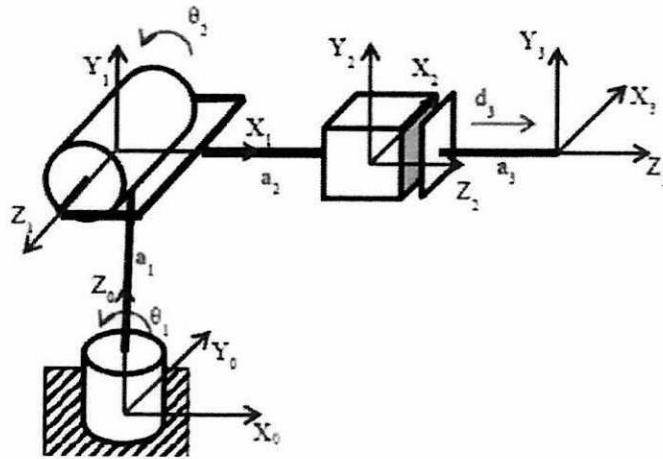

Figure Q1(c)

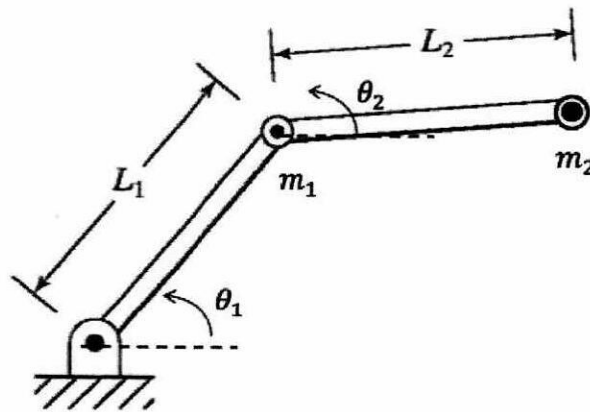

Figure Q3