



UNIVERSITI TUN HUSSEIN ONN MALAYSIA

**FINAL EXAMINATION
SEMESTER II
SESSION 2015/2016**

COURSE NAME : DYNAMIC
COURSE CODE : DAM 20903
PROGRAMME CODE : 2 DAM
EXAMINATION DATE : JUNE / JULY 2016
DURATION : 3 HOURS
INSTRUCTION : ANSWERS FIVE (5) QUESTIONS ONLY

THIS QUESTION PAPER CONSISTS OF SEVEN (7) PAGES

- Q1** (a) Define the kinematic and kinetic. (4 marks)
- (b) If a car is moving at 90 km/h and it rounds a corner, also at 90 km/h, does it maintain a constant speed and a constant velocity? Explain your answer. (6 marks)
- (c) Two balls P and Q moving at the same time from point A to point B in linear motion as shown in **Figure Q1(c)**. Ball P moves with constant velocity of 8 m/s while ball Q moves with initial velocity 1 m/s and constant acceleration of 2 m/s². If both of the balls meet at point B, determine;
- (i) the time taken of ball P to move from point A to point B.
 - (ii) the distance of AB.
 - (iii) the velocity of the ball Q when reached at point B. (10 marks)
- Q2** (a) Give the definition of rectilinear and curvilinear motions. (4 marks)
- (b) Explain **three (3)** types of acceleration in kinematics of particle. (6 marks)
- (c) A motorist is traveling on curved section of highway at 88 m/s. The motorist applies brakes causing a constant deceleration rate as shown in **Figure Q2(c)**. Knowing that after 8 s the speed has been reduced to 66 m/s,
- (i) draw the kinematic diagram of point A.
 - (ii) calculate the tangential and normal components of acceleration.
 - (iii) determine the magnitude of acceleration and direction of the automobile when it is at point A. (10 marks)

- Q3** (a) Define the newton's second law of motion. (4 marks)
- (b) A 5 kg mass and 3 kg mass are connected over a pulley by a light inextensible string. When the masses are released from rest, calculate:
- (i) the acceleration of each mass.
 - (ii) the tension in the spring.
- (used gravity, $g = 9.81 \text{ m/s}^2$) (6 marks)
- (c) A mini train containing 3 bags of cement moves down the hilly track with 30 degree inclinations shown in **Figure Q3(c)**. The train reaches constant velocity at 18 km/h without any external force acting on it. After the train moves down, it passes through the horizontal route until it stops. Friction resistance is uniform along the way. The mass of the mini train is 30 kg and the mass of 1 bag of cement is 10 kg.
- (i) determine the horizontal distance travelled by the train.
 - (ii) if the number of cement bags is reduced, what happens to the friction force and horizontal route distance?
- (10 marks)
- Q4** (a) Define the different between particles and rigid bodies. (4 marks)
- (b) Explain the **three (3)** types of planar rigid body motion. (6 marks)
- (c) The double gear rolls on the stationary lower rack: the velocity of its center is 1.2 m/s as shown in **Figure Q4(c)**. The point *C* is in contact with the stationary lower rack and, instantaneously has zero velocity, determine;
- (i) the angular velocity of the gear.
 - (ii) the velocities of the upper rack *R* and point *D* of the gear.
- (10 marks)

- Q5** (a) Describe briefly about dynamics of rigid bodies. (4 marks)
- (b) Explain the absolute motion analysis for particles and rigid bodies. (6 marks)
- (c) The 20 kg slender rod shown in **Figure Q5(c)** is rotating in the vertical plane, and at the instant shown it has an angular velocity of $\omega = 5$ rad/s. Constant couple moment $M = 60$ Nm. Determine the rod's angular acceleration and horizontal and vertical component reaction. (10 marks)
- Q6** (a) Define the conservation of energy and state the formula. (4 marks)
- (b) Explain the conservative force and potential energy in detail. (6 marks)
- (c) The rod AB has a mass of 10 kg and piston B is attached to a spring of constant $k = 800$ N/m as shown in **Figure Q6(c)**. The spring is un-stretched when $\theta = 0^\circ$. Neglect the mass of the pistons. Determine;
- (i) the angular velocity of rod AB if the rod is released from rest when $\theta = 30^\circ$.
- (ii) the potential and kinetic energy of the rod AB at state's initial and final position. (10 marks)

-END OF QUESTIONS -

FINAL EXAMINATION

SEMESTER / SESSION : SEM II / 2015/2016
COURSE NAME : DYNAMIC

PROGRAMME CODE : 2 DAM
COURSE CODE : DAM 20903

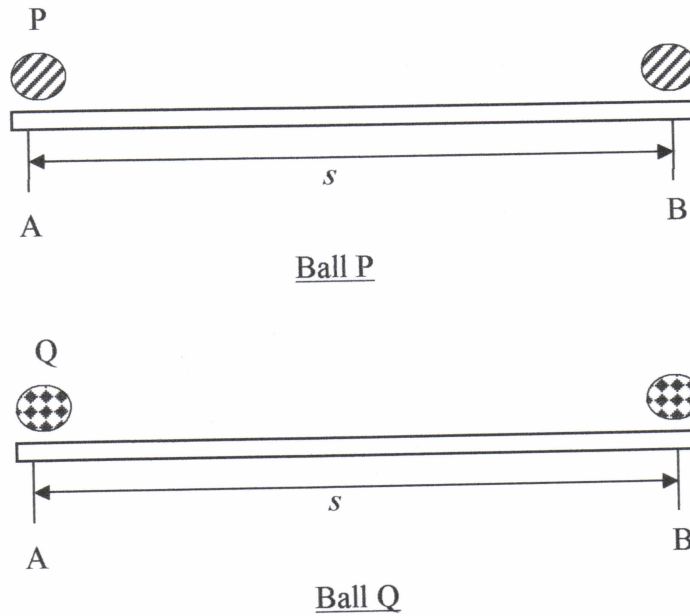

Figure Q1(c)

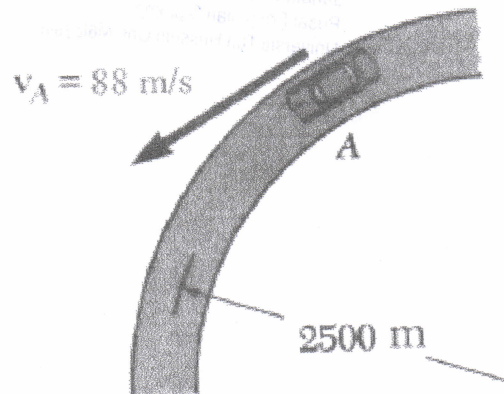

Figure Q2(c)

FINAL EXAMINATION

SEMESTER / SESSION : SEM II / 2015/2016
COURSE NAME : DYNAMIC

PROGRAMME CODE : 2 DAM
COURSE CODE : DAM 20903

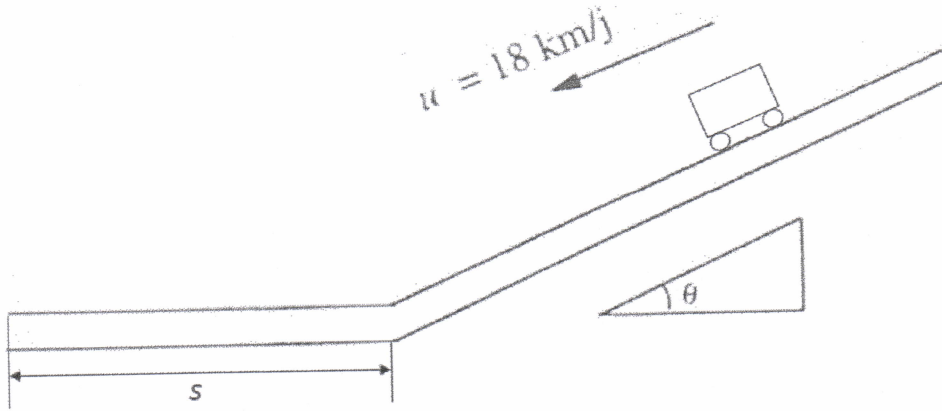

Figure Q3(c)

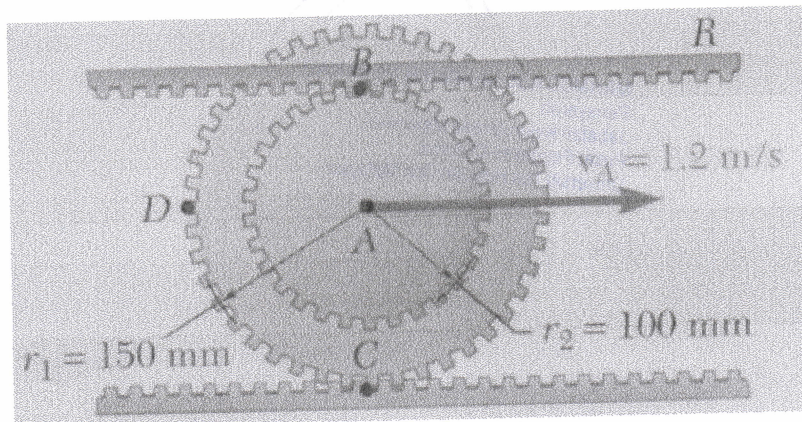

Figure Q4(c)

FINAL EXAMINATION

SEMESTER / SESSION : SEM II / 2015/2016
COURSE NAME : DYNAMIC

PROGRAMME CODE : 2 DAM
COURSE CODE : DAM 20903

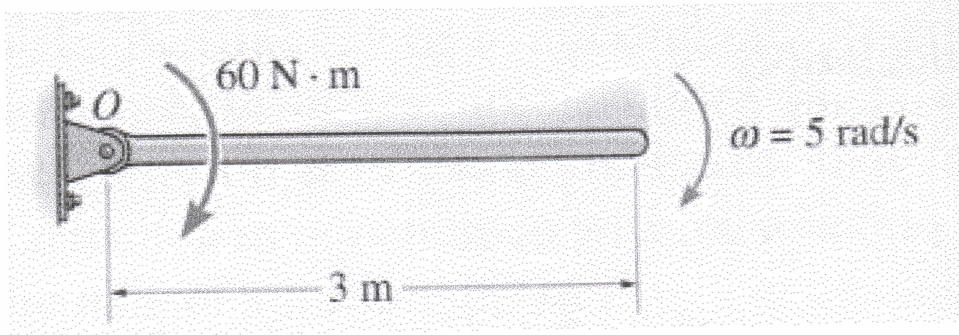

Figure Q5(c)

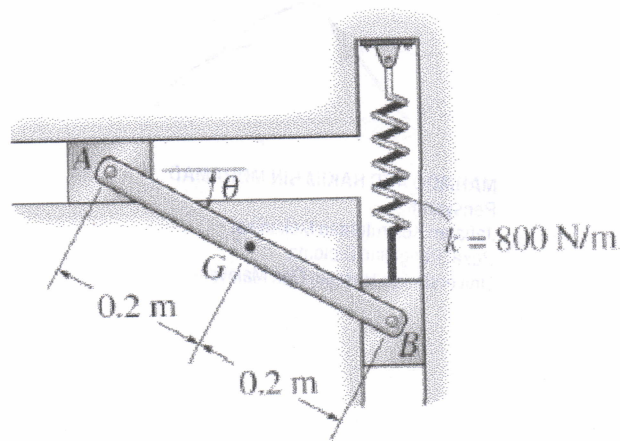

Figure Q6(c)