



UNIVERSITI TUN HUSSEIN ONN MALAYSIA

**FINAL EXAMINATION
SEMESTER II
SESSION 2015/2016**

COURSE NAME : MICROCONTROLLER
COURSE CODE : DAE 32203
PROGRAMME : 2 DAE
EXAMINATION DATE : JUNE/ JULY 2016
DURATION : 2 HOURS 30 MINUTES
INSTRUCTION : **PART A: ANSWER ALL
QUESTIONS
PART B: ANSWER ALL
QUESTIONS
PART C: ANSWER ONE (1)
QUESTIONS ONLY**

THIS QUESTION PAPER CONSISTS OF **FIFTEEN(15)** PAGES

PART A : Objectives
(30 marks)

- Q1** Microprocessor needs external peripherals to make it functional or become a computer. It also perform _____ in such cases input/output is undefined such as developing games, websites and photo editing.
- A. single tasks
 - B. simple tasks
 - C. complex tasks
 - D. multiple tasks

Question 2 based on Statement 1.

System bus is a collection of wires carrying information within

Statement 1

- Q2** What are the three types of system busses?
- A. address, data and system busses
 - B. address, data and control busses
 - C. address, input and output busses
 - D. address, general and control busses
- Q3** The prescaler can be the CPU clock frequency/rate or may be some higher or lower frequency. The purpose of the **prescaler** is
- A. to allow the timer to be clocked at the rate you desire.
 - B. to count either regular clock pulses or irregular event pulses
 - C. to use for writing programs or subroutines for generating pulses of various duration
 - D. All the above

Question 4 is based on Figure 1.

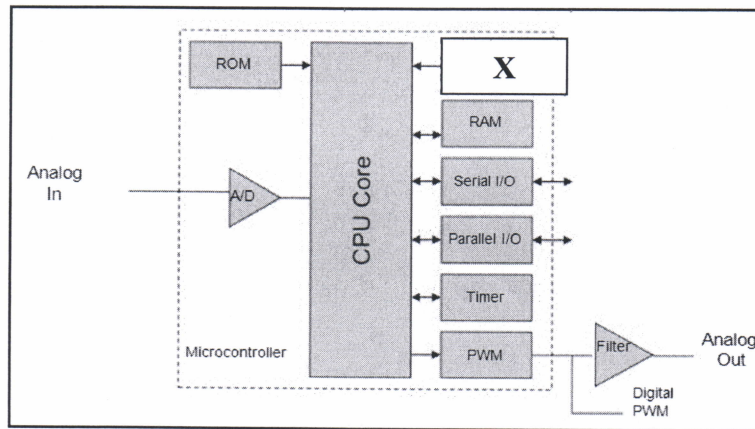

Figure 1: The Architecture of Microcontroller

Q4 What is the function of X?

- A. To store user data
- B. To store fixed user data
- C. To store and erase user data
- D. To store and erase user data electronically

Q5 Which of the following is true?

- I. The timer TMR0 module is an 8-bit timer/counter.
- II. Watchdog is a mechanism which microcontroller uses to defend itself against programs getting stuck.
- III. Interrupts are a mechanism of a microcontroller which enables it to respond to some events at the moment they occur.
- IV. Port is a group of pins on a microcontroller which can be accessed simultaneously or on which we can set the desired combination of zeros and ones.

- A. I and II only
- B. II and III only
- C. II and IV only
- D. All the above.

Question 6 and 7 are based on Figure 2.

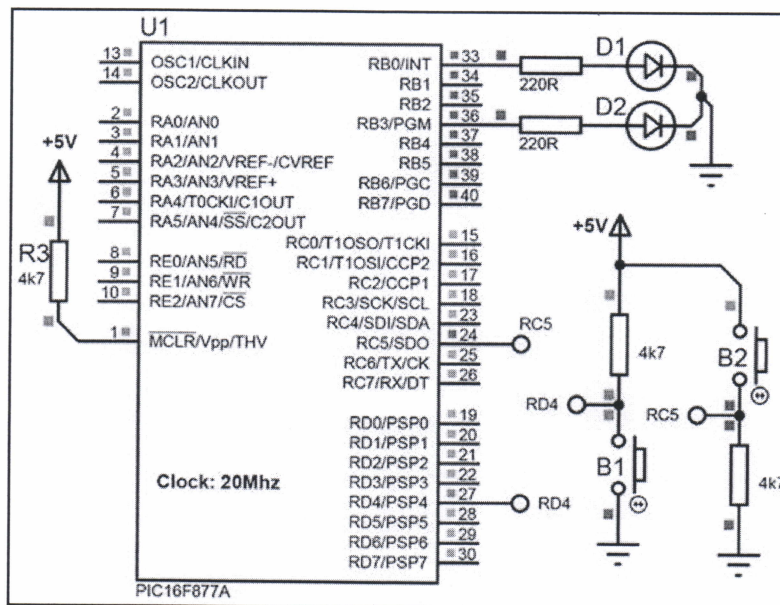

Figure 2: The Circuit Connection of Microcontroller

Q6 Which of the following is true?

- I. The input for the microcontroller is at RC5 only
- II. The input for the microcontroller is at RC5 and RD4
- III. The input value for the pin RC5 is 1 when button is pressed
- IV. The input value for the pin RD4 is 0 when button is not pressed

- A. I and II only
- B. II and III only
- C. II and IV only
- D. II, III and IV only

Q7 What is the input value for the pin RD4 when button is not pressed?

- A. 0
- B. 1
- C. 2
- D. 6

Question 8 based on Statement 2.

```

void interrupt (void)
{
    LED2 = 1;
    Delay_ms(5000);
    LED2 = 0;
    INTF = 0;
}
void main (void)
{
    GIE = 1;
    INTE = 1;
    TRISC = 0b00000000;
    PORTC = 0b00000000;
    TRISB = 0b00000001;
    PORTB = 0b00000000;
    while(1)
    {
        LED1 = ~LED1;
        Delay_ms(1000);
    }
}

```

Statement 2

- Q8** Which of the following is true?
- No software delay used in the programming code.
 - LED1 always blinking every 1s by hardware timer.
 - LED1 is always blinking every 1s and interrupt occurred every 1 second.
 - LED1 is always blinking every 1s and LED2 turn on for 5s when interrupt occurred.
- Q9** There are 8 data buses and 10 address buses connected between CPU and memory. Considering 1Kb is equal to 1024bytes, calculate the size of the memory for this microcontroller.
- 1 kbyte
 - 2 kbyte
 - 3 kbyte
 - 4 kbyte
- Q10** Serial Peripheral Interface (SPI) is an interface bus used for short distance communication commonly used to
- send data between microcontrollers and small peripherals
 - connect to an I/O modules is often referred to peripheral device
 - carry the CPU-generated address signals out to memory and to I/O devices.
 - carry signals from the CPU to external devices, and from external devices to the CPU.

Question 11 is based on Statement 3.

```

unsigned int adc;
void main()
{
    ADCON1= 0x80;
    TRISA = 0xFF;
    TRISC = 0x3F;
    TRISB = 0;
    do
    {
        adc = ADC_Read(1);
        PORTB = adc;
        PORTC = adc >> 2;
    } while(1
    
```

Statement 3

Q11 Which result channel that 10-bit AD conversion obtained from this programming code?

- A. Port A Channel 0
- B. Port A Channel 1
- C. Port B Channel 0
- D. Port B Channel 1

Q12 Inter-Integrated Circuit is a two wire serial interface. Common I²C bus speeds are the _____ standard mode and the _____ low-speed mode.

- A. 10 kbit/s, 100 kbit/s
- B. 100 kbit/s, 10 kbit/s
- C. 100 kbit/s, 1000 kbit/s
- D. 1000 kbit/s, 100 kbit/s

Q13 Prescaler register is used to control the speed of TMR0 overflow. We can control how quickly and slowly overflow can occur. By loading a value into the _____ register we can control the count until an overflow occurs.

- A. TMRO
- B. overflow
- C. prescaler
- D. oscillator

Question 17 and 18 are based on Figure 4.

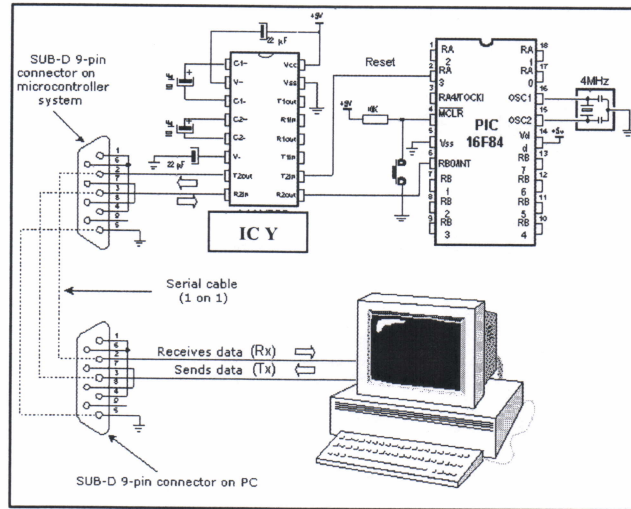

Figure 4: The Circuit Connection of UART

Q17 In order to connect a microcontroller to a serial port on a PC computer, we need to adjust the level of the signals so communicating can take place. Name one chip specially designed for this task.

- A. MAX232
- B. MAX293
- C. MAX2003
- D. MAX2003D

Q18 Connecting a microcontroller to a PC via **IC Y** line interface chip creates a file RS232.inc which contains a group of macros used for serial communication. Which of the following is true on the using of the **RS232text** macros for serial communication?

- A. Macro for sending ASCII value of a specified text.
- B. Macro for initializing the pin for transmitting data.
- C. Macro for sending ASCII value of data found in W register.
- D. Macro for sending ASCII value of decimal digits of 8-bit variable.

Q19 USB device communication is based on *pipes* (logical channels). A pipe is a connection from the host controller to a logical entity, found on a device, and named an endpoint. During USB communication data is transmitted as _____.

- | | |
|----------|-----------|
| A. set | C. group |
| B. array | D. packet |

Q20 Compute the **Overflow time** for the given information;
A crystal with 131072Hz, the prescaler setting bits PS2: PS0 to 010 (1:128) and assume the value loaded into the timer register TMR0 is decimal 0 (counting from 0).

- A. 100 us
- B. 10000 us
- C. 1000 ms
- D. 100000 ms

MAJLIS BAHASAWA
Pusat Penyelidikan
Kementerian Pendidikan
Malaysia

PART B : Subjectives
(40 marks)

- Q1** (a) Define Microcontroller. (3 marks)
- (b) Give **two (2)** differences between Microcontroller and Microprocessor. (4 marks)
- (c) Explain briefly the advantages of higher programming language. (3 marks)
-
- Q2** (a) **Figure Q2(a)** shows the memory structure of microcontroller. There are eight (8) data buses and twelve (12) address buses connected between CPU and memory. Considering 1Kb is equal to 1024 bytes, calculate the size of the memory for this microcontroller. (2 marks)
- (b) Give description for each line of C programming syntax below.
- ```
TRISB = 0b00000000;
PORTB = 0b00000000;
TRISA = 0b00010000;
```
- (3 marks)
- (c) All microcontrollers require an oscillator (clock) to operate. Explain in detail the function of oscillator in microcontroller. (5 marks)
- 
- Q3** (a) ADC is a unit in most modern microcontroller. Explain the purpose of having ADC unit in microcontroller. (1 marks)
- (b) One of the specifications of ADC is resolution. Give a reason why do we need that. (2 marks)
- (c) Give **three (3)** examples of analog signals around us. (3 marks)
- (d) List all registers associate with an ADC. (4 marks)

- Q4** Below is a list of C code that should perform as the LED turn ON once the button is pressed. It will behave in endless loop. But there are some syntax error during compiling the code. Identify the error and rewrite the correct one.

```
#define BUTTON PORTA.F4; //Button at PORTA b it 4
#define LED PORTB.F0; //LED at PORTB bit 0
void main()
{
 TRISB = 0b00000000; //All bit at PORTB is output
 PORTB = 0b00000000; //Clear (give 0V) at all PORTB output
 ADCON1 = 0b00000110; //Set PORTA as digital input
 TRISA = 0b00010000; //Set direction of bit 4 PORTA as input
 while() //endless loop
 {
 if (BUTTON == 0); //if button is pressed
 {
 LED = 1; //LED at PORTB bit 0 switch ON
 }
 else
 {
 LED = 0; //LED at PORTB bit 0 switch OFF
 }
 }
 //end of while
}
//end of main()
```

(10 mark)

**PART C**  
**(30 marks)**

- Q5** Stepper motors are very different from a regular DC motors. Instead of spinning like DC motors do, stepper motor steps at a specific resolution for each pulse.

Circuit in **Figure Q 5** operates by showing the direction of stepper motor rotation into LCD display and also on LED when one of the direction buttons is pressed. Write a C program to rotate the stepper motor with direction of button pressed and show the direction of rotation on LED and LCD.

- (a) Draw the flowchart of the program task.

(10 marks)

- (b) Write the main programme of the condition given to complete the programme.

(20 marks)

- Q6** Based on the circuit **Figure Q 6**, you are required to write a relay applications using C language based on the condition below:

*When button ON is pressed the lamp L2 lights up and LED1 will turn on for 3 seconds and turn off for 3 seconds continuously. When the button OFF is pressed the lamp L2 lights off and LED1 will turn off as well. The program must be in infinite loop and while in standby mode the LED1 is keep turning on.*

- (a) Draw the flowchart of the program task.

(15 marks)

- (b) Write the main program of the condition given to complete the programme.

(15 marks)

**Q7** (a) **Figure Q7** shows the circuit of temperature sensor LM35 which analog input to a microcontroller. The output voltage of LM35 is proportional to the temperature by 0.1V: 1°C. Voltage reference(Vref) used is +5V. Show the calculation to find;

- (i) ADC value when Vin to AN2 is 4.5V
- (ii) Temperature value in degree celcius when Vin to AN2 is 3V

(5 marks)

(b) Write a C program for temperature application on PIC 16F877A based system. The system should show the current temperature value in degree Celsius on the LCD and two LEDs should active base on the table below:

|                    | <b>LED D1</b> | <b>LED D2</b> | <b>Alarm</b> |
|--------------------|---------------|---------------|--------------|
| <b>Above 50° C</b> | ON            | OFF           | ON           |
| <b>Below 50° C</b> | OFF           | ON            | OFF          |

(25 marks)

**-END OF QUESTION-**

FINAL EXAMINATION

SEMESTER / SESSION: SEM II / 2015/2016  
COURSE NAME : MICROCONTROLLER

PROGRAMME CODE: 2 DAE  
COURSE CODE : DAE 32203

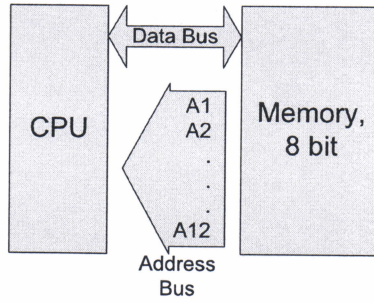

FIGURE Q2(a)

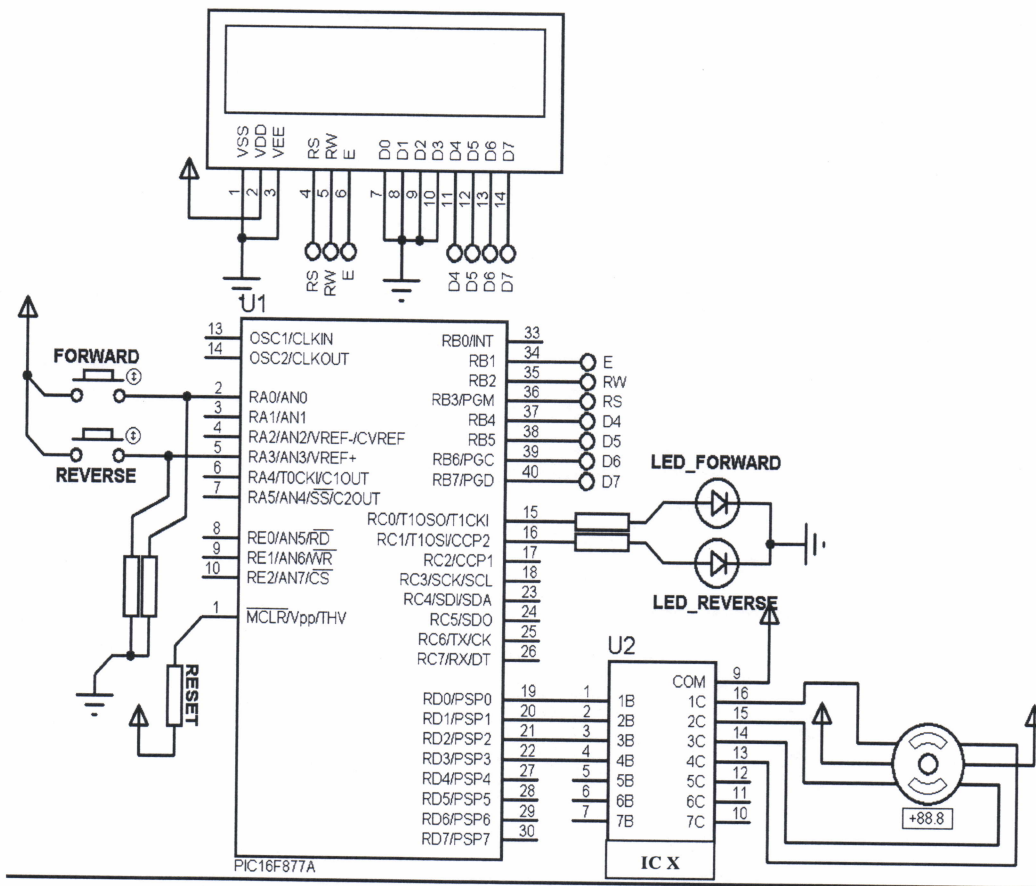

FIGURE Q5



